

**OUT
DO
OR**

2026

**OUT
DO
OR**

20**26**

DESIGN RAFFAELLO GALIOTTO



Scenografie all'aria aperta

NUOVE PROSPETTIVE DEL VIVERE ALL'ARIA APERTA.

IMMERSI NEL VERDE DI GIARDINI E BALCONI, AL RIPARO DI PERGOLE E PORTICATI, AFFACCIATI SU PANORAMI DI TERRAZZE SUL MARE O AL COSPETTO DI SUNTUOSE MONTAGNE.

DOVE IL FASCINO DELL'OPEN AIR INCONTRA QUELLO DEGLI ELEMENTI D'ARREDO, GLI AMBIENTI ESTERNI PRENDONO VITA CON LE NOSTRE COMPOSIZIONI, DISEGNATE PER DEFINIRE GLI SPAZI ALL'APERTO ALL'INSEGNA DEL DESIGN E DI UN RICERCATO VENTAGLIO CROMATICO CHE SPOSA A TUTTOTONDO LE ESIGENZE DELL'OUTDOOR LIVING CONTEMPORANEO.

ATMOSFERE SUGGERITIVE E RILASSANTI INCORNICIANO L'ELEGANZA DI CONFORTEVOLI COLLEZIONI DALLE LINEE PULITE E AVVOLGENTI, ERGONOMICHE E CONCEPITE SECONDO LA MASSIMA FUNZIONALITÀ A FAVORE DELLE PERSONE E DEL LORO SPAZIO VITALE.

ISPIRATI ALLA BELLEZZA E ALLA PUREZZA DELLA NATURA, I NOSTRI PRODOTTI LA RIEVOCANO FIN NEI COLORI, E NE RIPRENDONO IL VALORE NELL'IMPRONTA PROFONDAMENTE GREEN.

SONO INFATTI REALIZZATI IN MATERIALI RICICLABILI DI ALTA QUALITÀ, INTERAMENTE IN ITALIA, NONCHÉ PROGETTATI IN OTTICA DI ELEVATA RESISTENZA E DURABILITÀ NEL TEMPO.

Outdoor settings

NEW PERSPECTIVES OF OUTDOOR LIVING.

SURROUNDED BY THE GREENERY OF GARDENS AND BALCONIES, SHELTERED BY PERGOLAS AND PORCHES, ON TERRACES OVERLOOKING THE SEA OR WITH MAJESTIC MOUNTAINS IN VIEW.

WHERE THE APPEAL OF THE OPEN AIR ENCOUNTERS FURNITURE ELEMENTS, OUTDOOR ENVIRONMENTS COME TO LIFE WITH OUR COMPOSITIONS. THEY ARE DESIGNED TO CREATE OUTDOOR SPACES FEATURING STYLISH DESIGN AND A SOPHISTICATED RANGE OF COLOURS THAT PERFECTLY MEETS THE NEEDS OF CONTEMPORARY OUTDOOR LIVING.

EVOCATIVE AND RELAXING ATMOSPHERES EMBRACE THE ELEGANCE OF COMFORTABLE COLLECTIONS WITH CLEAN, ENVELOPING AND ERGONOMIC LINES, DESIGNED WITH THE UTMOST FUNCTIONALITY FOR THE BENEFIT OF PEOPLE AND THEIR LIVING SPACES.

INSPIRED BY THE BEAUTY AND PURITY OF NATURE, OUR PRODUCTS ALSO EVOKE NATURE IN THEIR COLOURS, REFLECTING ITS VALUE IN THEIR EXTREMELY GREEN FOOTPRINT. MADE OF HIGH-QUALITY RECYCLABLE MATERIALS, PRODUCED ENTIRELY IN ITALY, THEY ARE DESIGNED TO BE HIGHLY RESISTANT AND LONG-LASTING.

INDEX

10	MAXIMO MODULAR SYSTEM	70	SET RIO BENCH ALU	94	NET COLLECTION
33	KOMODO MODULAR SYSTEM	75	PIAVE	109	DOGA COLLECTION
44	TEVERE SYSTEM	78	PLANO	116	FOLIO COLLECTION
61	RIO SYSTEM	84	ATLANTICO	121	TECHNICAL DETAILS





MAXIMO cactus / timo Sunbrella®
MAXIMO TAVOLINO 80 _ MAXIMO TAVOLINO 33 cactus



archiproducts
AWARDS
WINNER
SUSTAINABILITY



reddot winner 2025

MAXIMO MODULAR SYSTEM

LINEE PULITE E DIMENSIONI GENEROSE PER MAXIMO, DIVANO MODULARE CON STRUTTURA IN RESINA RIGENERATA E TESSUTI AD ALTA COMPONENTE RICICLATA CHE, A PARTIRE DAL SINGOLO MODULO POLTRONA, PERMETTE INNUMEREVOLI CONFIGURAZIONI PROGETTUALI.

MAXIMO, THE MODULAR SOFA WITH A REGENERATED RESIN FRAME AND FABRICS CONTAINING MUCH RECYCLED MATERIAL, FEATURES CLEAN LINES AND GENEROUS DIMENSIONS. STARTING WITH A SINGLE ARMCHAIR MODULE, YOU CAN CREATE COUNTLESS DESIGN LAYOUTS.





MAXIMO cactus / timo Sunbrella® _ MAXIMO TAVOLINO 33 cactus

MAXIMO OFFRE ANCHE ACCESSORI FUNZIONALI COME UN PORTAOGGETTI LATERALE E UN TAVOLINO CON PIANO ROTONDO, PENSATI PER ESSERE AGGANCIATI CON SEMPLICITÀ ALLA POLTRONA.

MAXIMO ALSO FEATURES FUNCTIONAL ACCESSORIES INCLUDING A SIDE ACCESSORY MODULE AND A LOW TABLE WITH A ROUND TOP, DESIGNED TO BE EASILY ATTACHED TO THE ARMCHAIR.

MAXIMO cactus / timo Sunbrella® _ MAXIMO PORTAOGGETTI cactus





MAXIMO terra / cannella Sunbrella® _ MAXIMO TAVOLINO 70 MINI _ MAXIMO TAVOLINO 60 MAXI terra



MAXIMO terra / cannella Sunbrella®
MAXIMO TAVOLINO 60 MAXI _ MAXIMO TAVOLINO 70 MINI terra

I TAVOLINI ROTONDI
FREESTANDING, DI DIVERSE
MISURE E ALTEZZE,
COMPLETANO E ASSOLVONO
OGNI TIPO DI ESIGENZA
PROGETTUALE, MIGLIORANDO
L'ESPERIENZA DI RELAX
ALL'ARIA APERTA.

*FREESTANDING ROUND
LOW TABLES, IN VARIOUS
DIMENSIONS AND HEIGHTS,
COMPLEMENT AND MEET
ALL DESIGN REQUIREMENTS,
ENHANCING THE OUTDOOR
RELAXATION EXPERIENCE.*



MAXIMO terra / cannella Sunbrella® _ MAXIMO TAVOLINO 60 MAXI





I CUSCINI AUTOCENTRANTI
VESTONO RICERCATE
TRAME TESSILI ALTAMENTE
PERFORMANTI PER
RESISTERE ALL'APERTO.
TUTTI SFODERABILI E LAVABILI.

*THE SELF-CENTRING CUSHIONS
ARE ADORNED WITH HIGH-
PERFORMANCE TEXTILES TO
WITHSTAND OUTDOOR USE.
THEY ALL HAVE WASHABLE
REMOVABLE COVERS.*

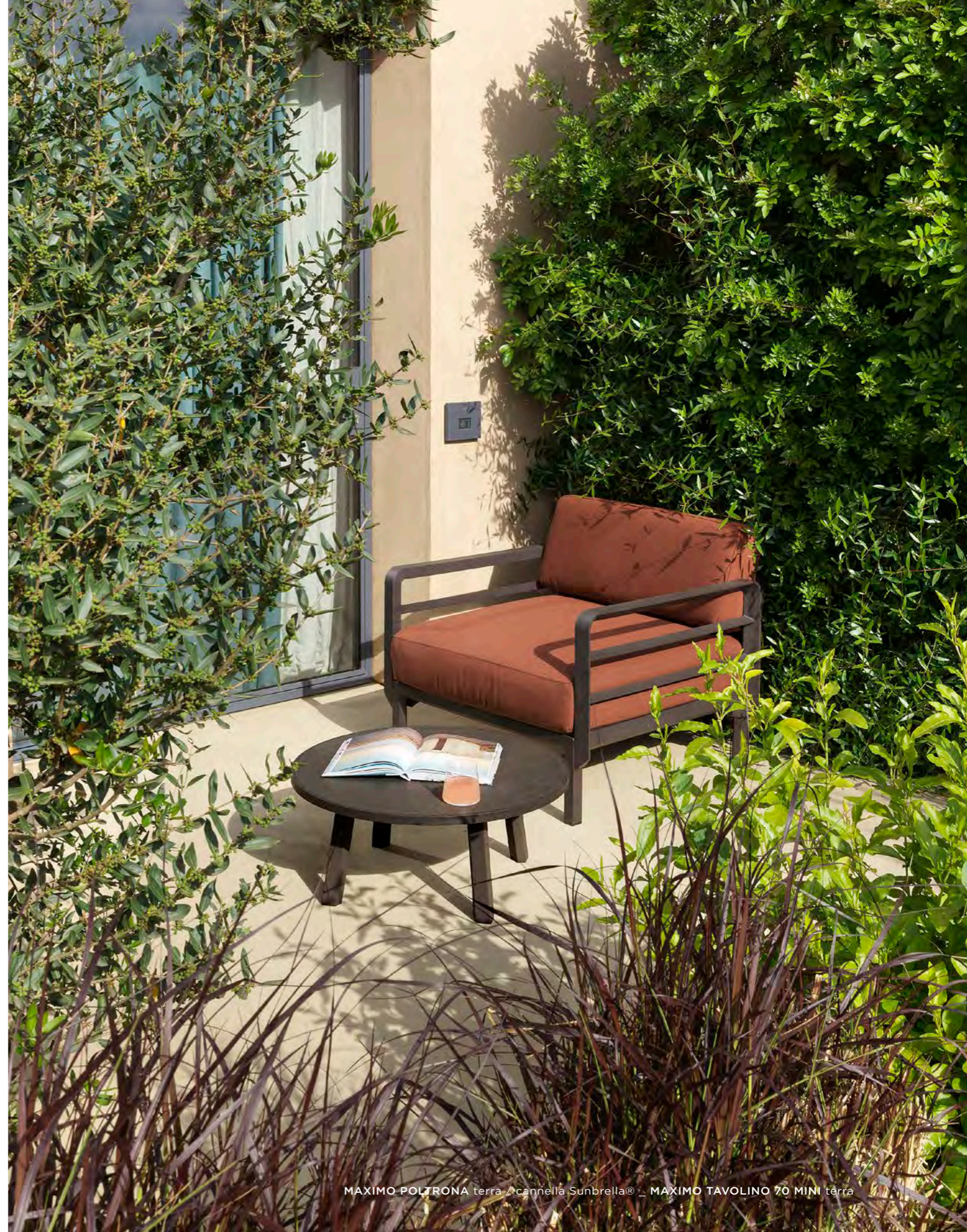





MAXIMO gesso / perla Sunbrella®





MAXIMO gesso / perla Sunbrella®



MAXIMO TAVOLINO 80 gesso





MAXIMO basalto / lava Sunbrella® _ MAXIMO TAVOLINO 80 basalto

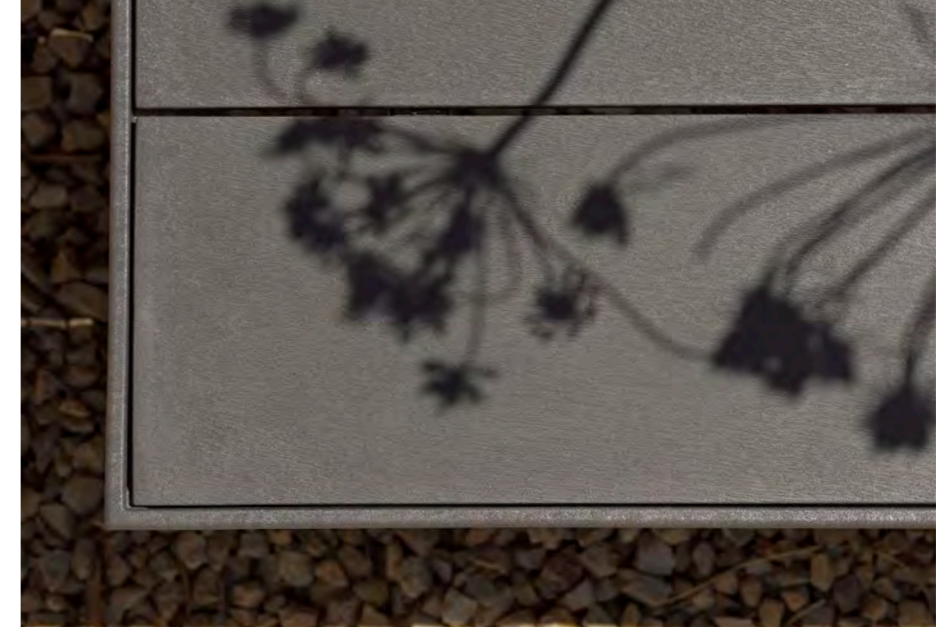

IL DESIGN SOBRIO E BILANCIATO DI MAXIMO SI SVILUPPA IN ORIZZONTALE, LA STRUTTURA È PIENA E RESA ESTETICAMENTE LEGGERA DALLA MODULAZIONE DELLE SEZIONI TRIANGOLARI E DAI DETTAGLI ARROTONDATI.

THE UNDERSTATED AND BALANCED DESIGN OF MAXIMO EXTENDS HORIZONTALLY. ITS STRUCTURE IS SOLID YET MADE AESTHETICALLY LIGHT WITH ITS MODULAR TRIANGULAR SECTIONS AND ROUNDED DETAILS.



MAXIMO POLTRONA basalto / lava Sunbrella®

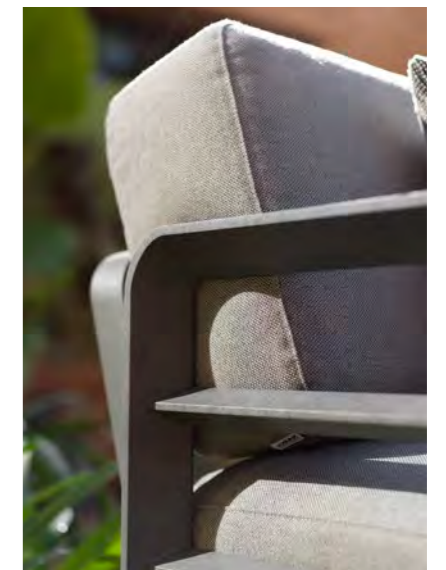
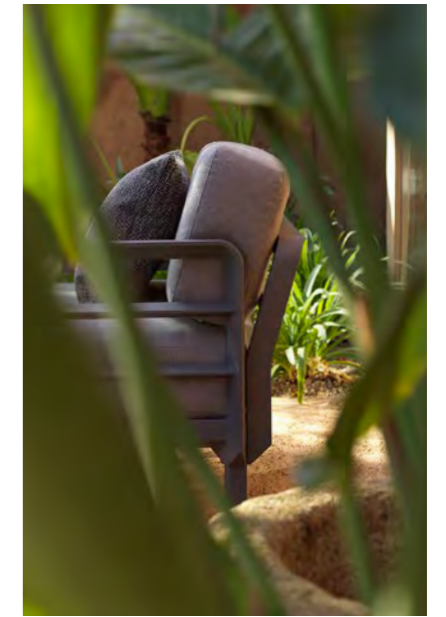

LA MODULARITÀ FLUIDA E ARMONICA, GRAZIE AL SISTEMA DI AGGANCIAMENTO DI SCHIENALE E BRACCIOLO, PERMETTE OGNI INTERPRETAZIONE PROGETTUALE COME LA CONFORTEVOLE MAXIMO POLTRONA, CONFIGURABILE DA SOLA O IN COMPOSIZIONE.

WITH THE FIXING SYSTEM FOR BACKRESTS AND ARMRESTS, ITS HARMONIOUS AND FLUID MODULARITY OFFERS ALL POSSIBLE DESIGN INTERPRETATIONS, SUCH AS THE COMFORTABLE MAXIMO ARMCHAIR, WHICH CAN BE CONFIGURED ON ITS OWN OR IN A COMPOSITION.



KOMODO antracite / rosa quarzo _ KOMODO TAVOLINO VETRO antracite / vetro



KOMODO MODULAR SYSTEM

ISPIRATO ALLA NATURA E AGLI INTRECCI DEI RAMI DELLE PIANTE, KOMODO È UN SISTEMA MODULARE DI SEDUTE PER L'OUTDOOR CON STRUTTURA IN RESINA FIBERGLASS E IMBOTTITI DALLA STRAORDINARIA FLESSIBILITÀ COMPOSITIVA.

INSPIRED BY NATURE AND THE LATTICE PATTERN OF TREE BRANCHES, KOMODO IS A MODULAR SEATING SYSTEM FOR OUTDOOR ENVIRONMENTS, FEATURING A FIBERGLASS RESIN FRAME AND PADDED ELEMENTS WITH EXTRAORDINARY COMPOSITIONAL VERSATILITY.



KOMODO bianco / rosa quarzo _ KOMODO TAVOLINO bianco



IL CONCEPT DI KOMODO SI BASA SU
UNA STRUTTURA RETICOLARE STABILE
ALLA QUALE SONO AGGANCIABILI SU
TUTTI I LATI, ATTRAVERSO SEMPLICE
ROTAZIONE, GLI SCHIENALI.

*THE CONCEPT OF KOMODO IS BASED ON A
STABLE GRID FRAME, TO WHICH BACKRESTS
CAN BE ATTACHED ON ALL SIDES WITH A
SIMPLE ROTATING MOVEMENT.*



KOMODO POLTRONA agave / avocado - giungla Sunbrella®



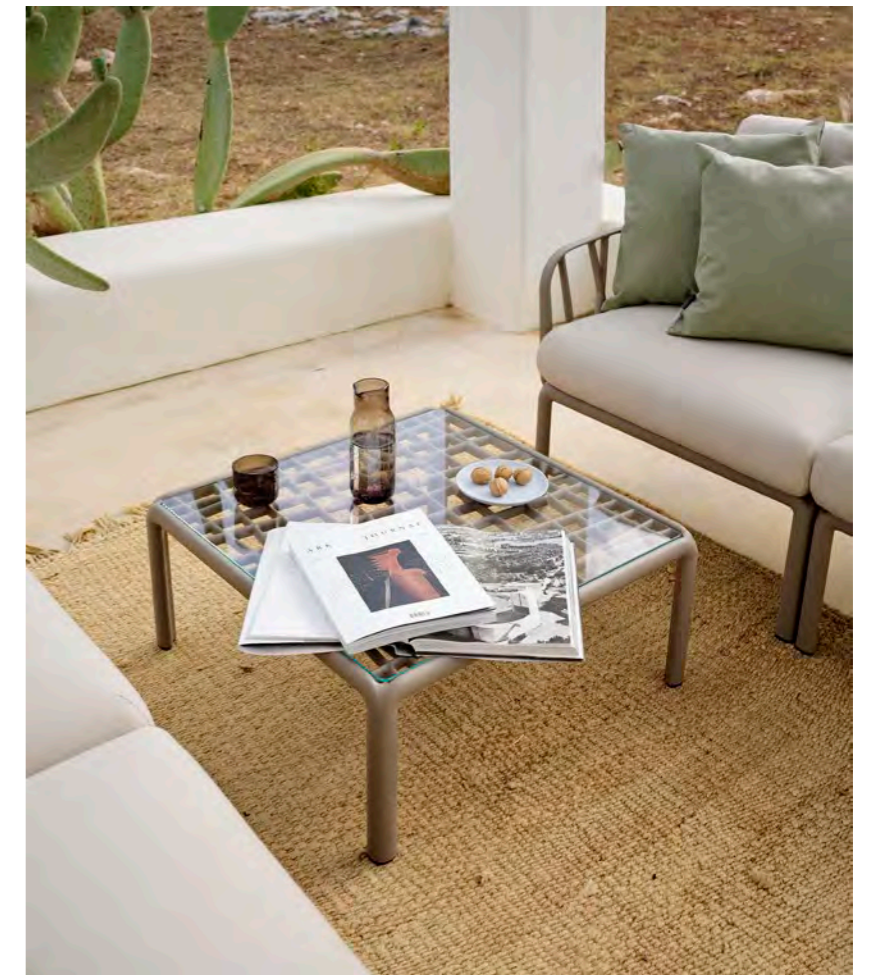

KOMODO tortora / canvas Sunbrella® _ KOMODO TAVOLINO VETRO tortora / vetro

L'AMPIO E FUNZIONALE KOMODO TAVOLINO È PROPOSTO CON PIANO IN VETRO O IN RESINA FIBERGLASS IN PERFETTO PENDANT CON IL DIVANO MODULARE.

THE SPACIOUS AND FUNCTIONAL KOMODO TAVOLINO IS A LOW TABLE AVAILABLE WITH A GLASS OR FIBERGLASS RESIN TOP PERFECTLY MATCHING THE MODULAR SOFA.



KOMODO bianco / ghiaccio Sunbrella® _ KOMODO OMBRA 2 bianco / velo white _ KOMODO TAVOLINO bianco



archiproducts
AWARDS
WINNER
SUSTAINABILITY



TEVERE 210 EXTENSIBLE tortora _ CASSIA ARMCHAIR borgogna

TEVERE SYSTEM

SOFISTICATA SOBRIETÀ STILISTICA, LINEE MORBIDE GIOCATE SULL'ASSENZA DI SPIGOLI E SULLA FORMA ARROTONDATA DELLA STRUTTURA PER TEVERE, TAVOLO DOGATO CON SISTEMA DI ALLUNGO CHE MANTIENE LE GAMBE ALLE ESTREMITÀ DEL PIANO PRESERVANDO UNA CURATA LINEA ESTETICA.

SOPHISTICATED STYLISTIC SIMPLICITY, SOFT LINES CENTRED ON THE ABSENCE OF SHARP EDGES AND THE ROUNDED SHAPE OF THE FRAME ARE THE DISTINCTIVE FEATURES OF TEVERE, A SLATTED TABLE WITH AN EXTENSION SYSTEM THAT KEEPS THE LEGS AT THE ENDS OF THE TOP WHILE ENSURING A NEAT AESTHETIC LINE.





TEVERE 210 EXTENSIBLE tortora _ CASSIA ARMCHAIR borgogna



TEVERE 210 EXTENSIBLE tortora _ CASSIA ARMCHAIR borgogna

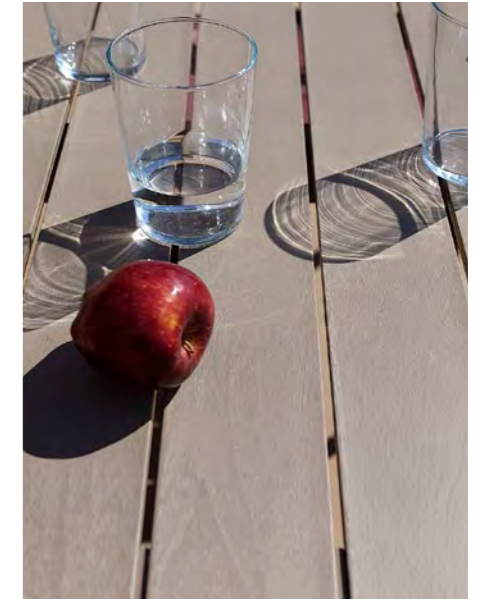

LE LINEE FLUIDE E SINUOSE DEL TAVOLO
ALLUNGABILE TEVERE SI ARMONIZZANO CON LE CURVE
ACCOGLIENTI DELLA COLLEZIONE DI SEDUTE CASSIA,
DANDO VITA A SCENOGRAFIE OUTDOOR
DAL FASCINO AUTENTICO E CONTEMPORANEO.

*THE FLUID AND SINUOUS LINES OF THE TEVERE
EXTENSIBLE TABLE ARE IN HARMONY WITH THE
EMBRACING CURVES OF THE CASSIA CHAIR COLLECTION,
RESULTING IN OUTDOOR SETTINGS
WITH AUTHENTIC AND CONTEMPORARY APPEAL.*



TEVERE 210 EXTENSIBLE corda _ TIBERINA ARMCHAIR corda



TEVERE 210 EXTENSIBILE corda _ TIBERINA ARMCHAIR corda



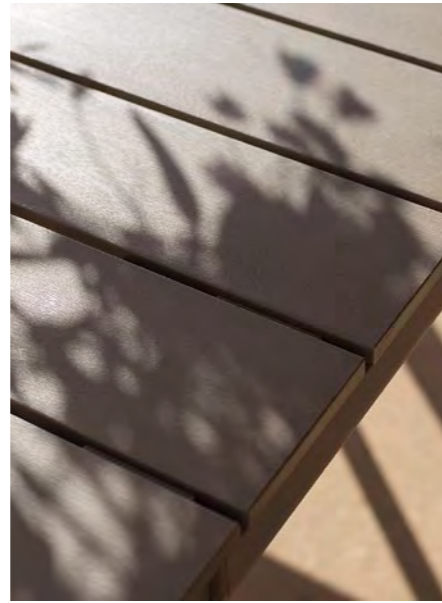

TEVERE 147 EXTENSIBLE tortora _ TIBERINA BISTROT tortora

DOGHE, DESIGN FLUIDO, GAMBE AFFUSOLATE: SONO I CARDINI DELL'ELEGANTE SET COMPOSTO DAL TAVOLO ALLUNGABILE TEVERE E DALLA SEDUTA CON E SENZA BRACCIOLI TIBERINA.

SLATS, A FLUID DESIGN AND TAPERED LEGS: THESE ARE THE KEY FEATURES OF THE ELEGANT SET COMPRISING THE TEVERE EXTENSIBLE TABLE AND THE TIBERINA CHAIR WITH OR WITHOUT ARMRESTS.





TEVERE 210 EXTENSIBILE corda _ DOGA ARMCHAIR _ DOGA BISTROT menta



TEVERE 210 EXTENSIBLE corda _ DOGA ARMCHAIR _ DOGA BISTROT menta

LA DINAMICITÀ DEL TAVOLO ALLUNGABILE
TEVERE INCONTRA L'EVOCATIVA
LEGGEREZZA DELLA COLLEZIONE DI
SEDUTE CON E SENZA BRACCIOLI DOGA.

*THE DYNAMIC APPEAL OF THE TEVERE
EXTENSIBLE TABLE MERGES WITH THE
IMPRESSIVE LIGHTNESS OF THE DOGA
COLLECTION OF CHAIRS WITH AND
WITHOUT ARMRESTS.*



RIO ALU 210 EXTENSIBILE antracite _ NET senape

RIO SYSTEM

CARATTERE DECISO E DESIGN PULITO PER IL TAVOLO ALLUNGABILE RIO CON PIANO IN RESINA DURELTOP E SOLIDA STRUTTURA IN ALLUMINIO VERNICIATO. DETTAGLI ARCHITETTURALI PER LA GAMBA A SEZIONE QUADRATA CHE SI INNESTA A FILO DEL PERIMETRO DEL PIANO, CONTRADDISTINTO DA UNA PERFETTA SEQUENZA DI DOGHE.

A DISTINCT CHARACTER AND A CLEAN DESIGN FOR THE RIO EXTENSIBLE TABLE WITH A DURELTOP RESIN TOP AND A STURDY, COATED ALUMINIUM FRAME. THE SQUARE-SECTION LEG FEATURES ARCHITECTURAL DETAILS WHILE FITTING FLUSH WITH THE PERIMETER OF THE TOP, FEATURING A PERFECT SEQUENCE OF SLATS.



RIO ALU 210 EXTENSIBILE antracite _ NET senape

IL VOLUME COMPATTO DEL TAVOLO SI
CONTRAPPONE ALLE TRASPARENZE DELLA
SCOCCA E ALLA RICERCATEZZA DEI COLORI
DELLA COLLEZIONE DI POLTRONCINE NET.

*THE COMPACT VOLUME OF THE TABLE
CONTRASTS WITH THE TRANSPARENCY OF
THE FRAME AND THE REFINED COLOURS OF
THE NET ARMCHAIR COLLECTION.*



L'ESSENZIALITÀ DELLE FORME DEL TAVOLO E LE GAMBE QUADRATE SPOSANO LE LINEE EQUILIBRATE E L'ASPETTO SCULTOREO DELLE SEDUTE CON E SENZA BRACCIOLI DELLA COLLEZIONE TRILL. ESTREMAMENTE CONFORTEVOLI, STABILI E VERSATILI PER L'UTILIZZO.

THE ESSENTIAL SHAPES OF THE TABLE AND SQUARE LEGS BLEND WITH THE BALANCED LINES AND THE SCULPTURAL APPEARANCE OF THE CHAIRS WITH AND WITHOUT ARMRESTS FROM THE TRILL COLLECTION. EXCEPTIONALLY COMFORTABLE, STABLE AND VERSATILE FOR USE.

RIO ALU 210 EXTENSIBLE antracite _ TRILL ARMCHAIR agave





RIO ALU 210 EXTENSIBLE antracite _ TRILL ARMCHAIR agave





RIO EXTENSIBLE bianco

RESIN TOP 25mm



RIO ALU EXTENSIBLE bianco

ALUMINIUM TOP 15mm



RIO ALU 140 EXTENSIBLE bianco _ NET bianco / senape _ BIT bianco

SET RIO BENCH ALU

—

ATMOSFERE INFORMALI E RILASSATE CON IL SET DOGATO COMPOSTO DA TAVOLO E PANCHE IN ALLUMINIO VERNICIATO CHE DEFINISCONO GLI AMBIENTI ESTERNI IN TOTALE LIBERTÀ. AMPIO E ROBUSTO, IL SET GIOCA SU UN DISEGNO PULITO E UN ASPETTO MATERICO PER UN RISULTATO CHE MASSIMIZZA DESIGN, COMFORT E FUNZIONALITÀ.

THE SLATTED SET CONSISTING OF A TABLE AND BENCHES IN COATED ALUMINIUM PROVIDES RELAXED AND INFORMAL ATMOSPHERES, ALLOWING YOU TO FREELY CREATE OUTDOOR ENVIRONMENTS. SPACIOUS AND STURDY, THE SET PLAYS ON A CLEAN DESIGN AND TEXTURED APPEARANCE RESULTING IN OPTIMISED DESIGN, COMFORT AND FUNCTIONALITY.





RIO ALU 210 FIX tortora _ RIO BENCH ALU tortora

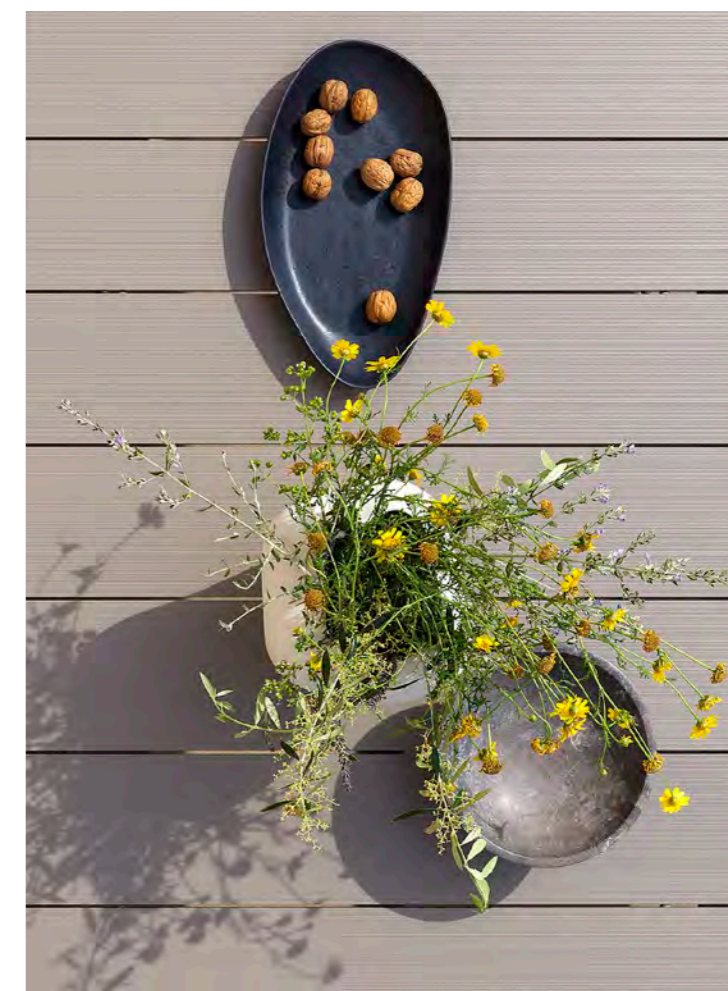

TAVOLO E PANCHE HANNO PIANI A
DOGHE IN ALLUMINIO VERNICIATO
CARATTERIZZATI DALLA PECULIARE
TEXTURE RIGHETTATA. LE GAMBE
SQUADRATE IN ALLUMINIO SONO A
FILO DEL PERIMETRO DEL PIANO E
DELLA SEDUTA.

*THE TABLE AND BENCHES FEATURE
SLATTED TOPS IN COATED
ALUMINIUM WITH A DISTINCTIVE
RIBBED TEXTURE. THE SQUARE
ALUMINIUM LEGS ARE FLUSH WITH
THE PERIMETER OF THE TOP
AND THE SEAT.*



PIAVE 160X90 antracite / antracite materia _ CASSIA BISTROT antracite



PIAVE

ALL'INSEGNA DELLA LEGGEREZZA E DELL'EQUILIBRIO DELLE FORME, PIAVE È UN TAVOLO CON PIANO IN LAMINATO MATERICO DALLO SPESSORE MOLTO SOTTILE, ANGOLI ARROTONDATI E SOLIDA STRUTTURA IN ALLUMINIO A SEZIONE ROTONDA.

SINTESI DI BELLEZZA, COMFORT E FUNZIONALITÀ, IL SUO DESIGN ESSENZIALE E RICERCATO LO RENDE IDEALE PER VIVERE CON STILE MOMENTI CONVIVIALI ALL'APERTO.

DISTINGUISHED BY LIGHT, BALANCED SHAPES, PIAVE IS A TABLE WITH A VERY THIN, TEXTURED LAMINATE TOP, ROUNDED CORNERS AND A STURDY ALUMINIUM FRAME WITH A ROUND CROSS SECTION.

A COMBINATION OF BEAUTY, COMFORT AND FUNCTIONALITY, ITS MINIMALIST AND REFINED DESIGN MAKES IT IDEAL FOR ENJOYING CONVIVIAL MOMENTS OUTDOORS IN STYLE.



IL DESIGN EMPATICO DELLA SEDUTA CASSIA, RICONOSCIBILE PER LE SUE DOGHE ORIZZONTALI STILIZZATE E PER I DETTAGLI STRUTTURALI DAL FORTE IMPATTO ESTETICO, SI FONDE CON LA NATURALE RAFFINATEZZA DEL TAVOLO PIAVE, DANDO VITA A UN INSIEME ARMONIOSO, PERFETTO PER VALORIZZARE OGNI AMBIENTE OUTDOOR CON PERSONALITÀ E STILE.

THE EMPATHIC DESIGN OF THE CASSIA CHAIR, RECOGNISABLE BY ITS STYLISED HORIZONTAL SLATS AND STRUCTURAL DETAILS WITH GREAT AESTHETIC APPEAL, BLENDS WITH THE NATURAL SOPHISTICATION OF THE PIAVE TABLE, CREATING A HARMONIOUS ENSEMBLE, IDEAL FOR ENHANCING EACH OUTDOOR SPACE WITH PERSONALITY AND STYLE.





PLANO corda / incenso

PLANO

—

TRA ELEGANZA E INNOVAZIONE, L'ESSENZA DEL RELAX PRENDE FORMA CON PLANO, LETTINO PRENDISOLE DALLE LINEE PULITE E ARMONIOSE UNITE A UNA SUPERFICIE AMPIA E ACCOGLIENTE PER UN BENESSERE SENZA COMPROMESSI.

WITH ELEGANCE AND INNOVATION, THE ESSENCE OF RELAXATION TAKES SHAPE WITH PLANO, THE SUN LOUNGER WITH CLEAN, HARMONIOUS LINES COMBINED WITH A COMFORTABLE, WIDE SURFACE OFFERING UNCOMPROMISING WELL-BEING.



PLANO corda / incenso _ NET TABLE 40 corda

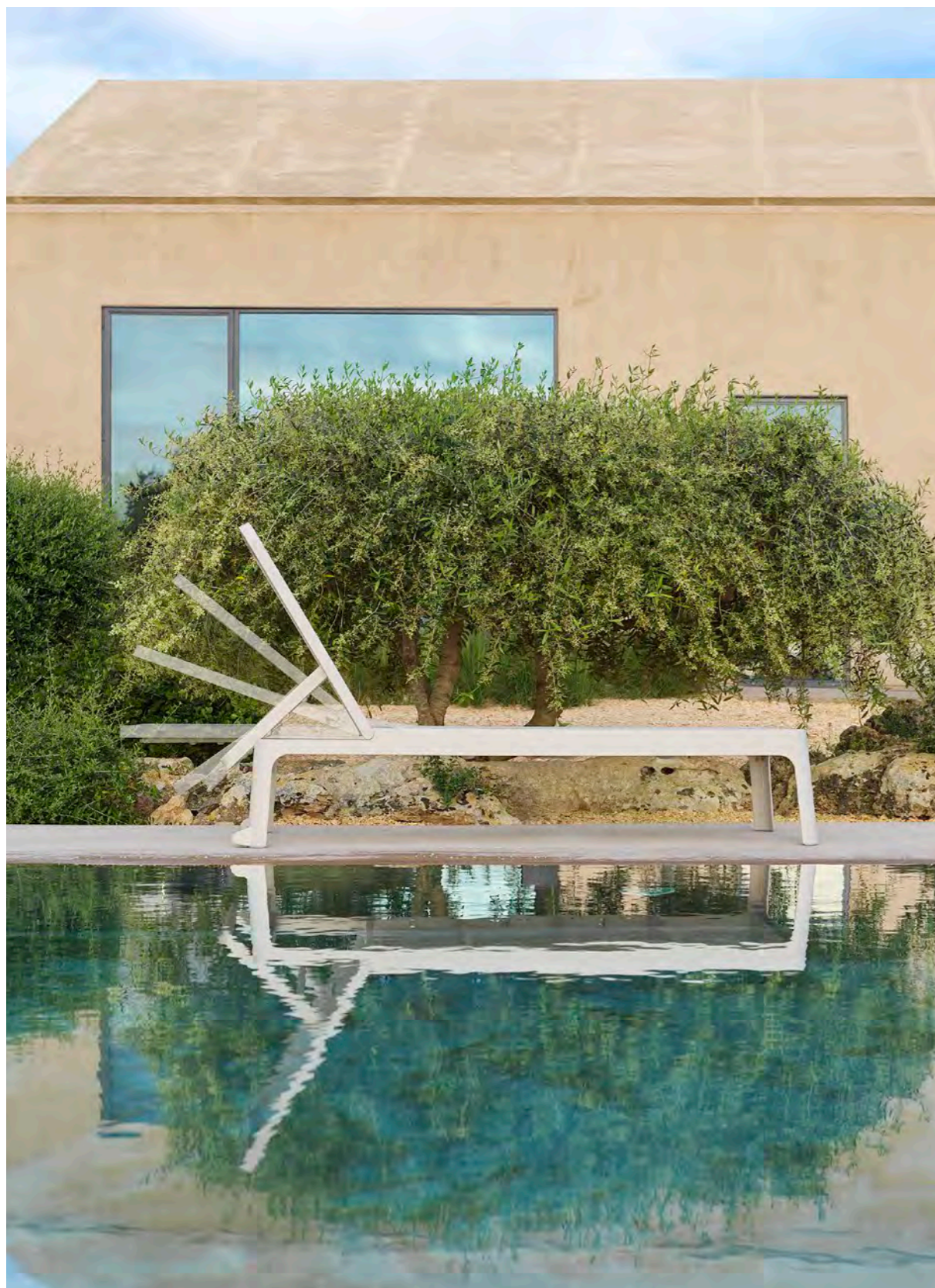

SCHIENALE REGOLABILE IN QUATTRO POSIZIONI, PIEDINI ANTISCIVOLO E RUOTE INTEGRATE: OGNI DETTAGLIO È STATO STUDIATO PER OTTIMIZZARE BENESSERE ED ESPERIENZA D'UTILIZZO.

FOUR-POSITION ADJUSTMENT FOR THE BACKREST, NON-SLIP FEET AND INTEGRATED CASTORS: EVERY DETAIL HAS BEEN DESIGNED TO OPTIMISE WELL-BEING AND THE USER EXPERIENCE.



PLANO corda / incenso _ NET TABLE 40 corda

IL MECCANISMO BREVETTATO CONSENTE
ALLO SCHIENALE DI RUOTARE CON
FLUIDITÀ FINO ALLA COMPLETA PLANARITÀ,
MIGLIORANDO COMFORT E IMPILABILITÀ.

*THE PATENTED MECHANISM ALLOWS THE
BACKREST TO ROTATE SMOOTHLY
UNTIL IT'S COMPLETELY FLAT, FOR EXTRA
COMFORT AND STACKABILITY.*



PLANO menta / mandorla _ NET TABLE 40 menta

ATLANTICO

PROGETTATO SU UNO SLANCIATO ARCO PORTANTE CHE CARATTERIZZA TUTTA LA STRUTTURA, ATLANTICO È UN LETTINO PRENDISOLE DELINEATO DA FORME ARROTONDATE. MASSIMA CURA DEI DETTAGLI E QUALITÀ DEI MATERIALI PER UN CONCEPT ESTETICO DAI TRATTI PURI ED ESSENZIALI, APPOSITAMENTE STUDIATI PER GARANTIRE UNA PERFETTA ERGONOMIA E UN BILANCIAMENTO UNIFORME DEL PESO.

DESIGNED WITH A SLENDER LOAD-BEARING ARCH SHAPE THAT IS A DISTINCTIVE FEATURE OF ITS ENTIRE FRAME, ATLANTICO IS A SUNLOUNGER WITH ROUNDED SHAPES. THE UTMOST ATTENTION TO DETAILS AND HIGH-QUALITY MATERIALS RESULT IN AN AESTHETIC CONCEPT WITH PURE AND ESSENTIAL FEATURES, SPECIFICALLY DESIGNED TO ENSURE OPTIMAL ERGONOMICS AND UNIFORM DISTRIBUTION OF WEIGHT.







ATLANTICO tortora / tortora _ POP tortora





ATLANTICO tortora / agave

STRUTTURA IN RESINA FIBERGLASS, TESSUTO
TRASPIRANTE E SCHIENALE RECLINABILE IN
QUATTRO DIVERSE POSIZIONI PER UN TOTALE
ABBANDONO AL RELAX.

*A FIBERGLASS RESIN FRAME, BREATHABLE
FABRIC AND A BACKREST RECLINING TO
FOUR DIFFERENT POSITIONS PROVIDE TOTAL
RELAXATION.*

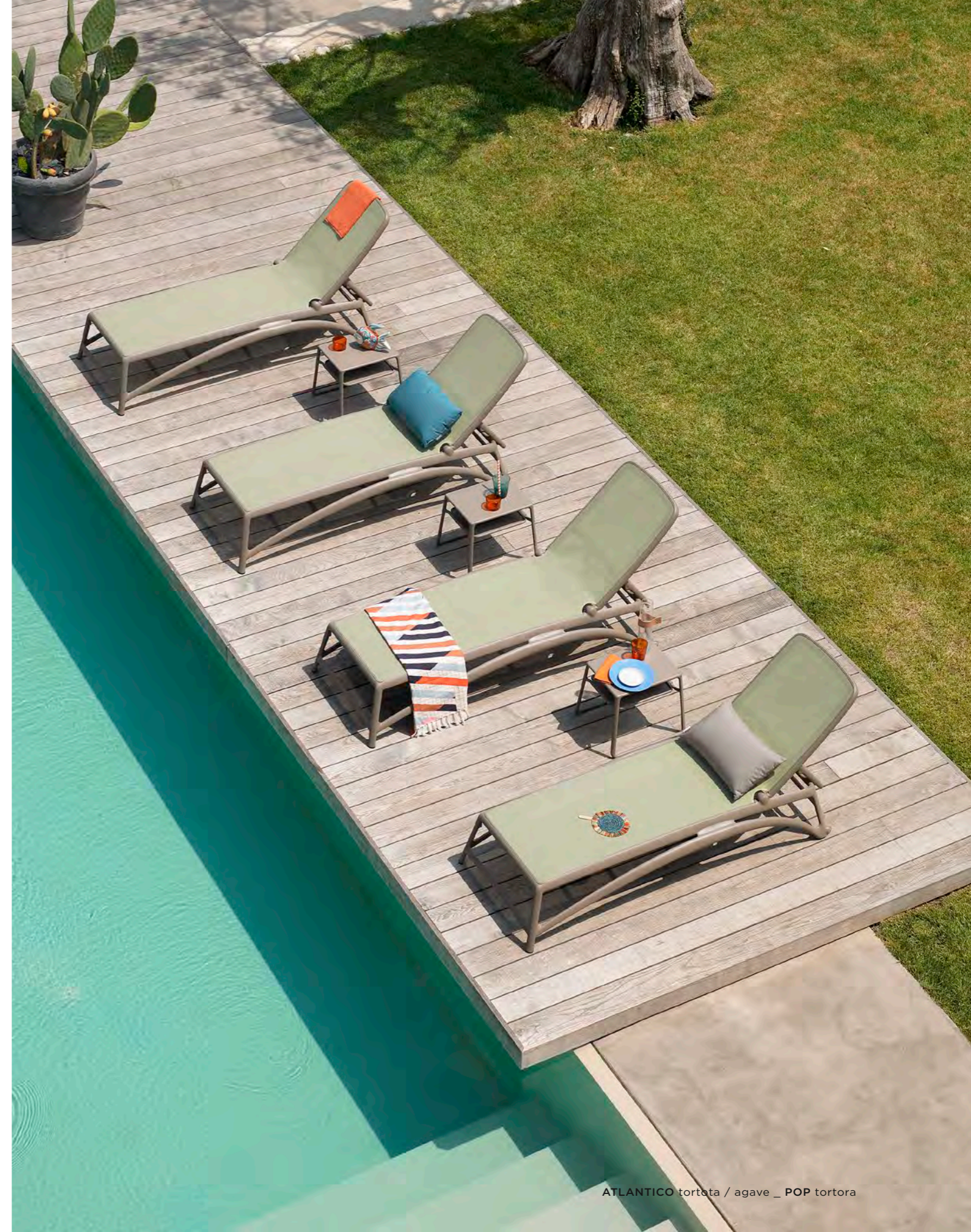

ATLANTICO tortora / agave _ POP tortora



ATLANTICO bianco / bianco _ POP bianco



NET LOUNGE tortora _ SPRITZ tortora

NET COLLECTION

EQUILIBRIO DI FORME, PROPORZIONI E COLORI PER UNA RAFFINATA COLLEZIONE IN RESINA FIBERGLASS CON SEDUTE, POLTRONCINE, POLTRONE RELAX, DIVANETTO E TAVOLI D'APPOGGIO ADATTI ALLA PROGETTAZIONE DI PERSONALI SCENOGRAFIE OPEN AIR.

BALANCED SHAPES, PROPORTIONS AND COLOURS CREATE A SOPHISTICATED COLLECTION IN FIBERGLASS RESIN, WITH CHAIRS, ARMCHAIRS, RELAXING ARMCHAIRS, A SOFA AND LOW TABLES THAT ARE IDEAL FOR CREATING PERSONAL SETTINGS OUTDOORS.





NET LOUNGE antracite / grigio Sunbrella® _ SPRITZ antracite



LA SCOCCA OPACA E LEGGERMENTE BOMBATA È DECORATA DA UN MOTIVO A FORI QUADRATI DISTRIBUITI UNIFORMEMENTE SU TUTTA LA SUPERFICIE DELLE SEDUTE, *LEITMOTIV* DELLA COLLEZIONE INSIEME ALLA RICERCATA PALETTE DI COLORI. AMPIO IL VENTAGLIO DI CUSCINI PER SEDUTA E POGGIATESTA.

THE MATT, SLIGHTLY ROUNDED STRUCTURE IS ADORNED WITH A SQUARE PERFORATED PATTERN EXTENDING EVENLY ACROSS THE ENTIRE SURFACE OF THE CHAIRS, A HALLMARK OF THE COLLECTION ALONG WITH THE SOPHISTICATED COLOUR PALETTE. A WIDE RANGE OF CUSHIONS IS AVAILABLE FOR THE CHAIRS AND HEADREST.





NET LOUNGE corallo _ SPRITZ tortora





NET LOUNGE senape _ NET TABLE 40 senape

FASCINO INNATO PER IL TAVOLINO D'APPOGGIO NET TABLE 40, CON PIANO QUADRATO, CARATTERIZZATO DAL MOTIVO TRAFORATO CHE CONTRADDISTINGUE L'INTERA LINEA DI SEDUTE NET. UN ABBINAMENTO IDEALE PER SOLUZIONI D'ARREDO OUTDOOR DOVE STILE E BENESSERE SI FONDONO.

THE FREESTANDING NET TABLE 40 LOW TABLE OFFERS NATURAL CHARM, WITH ITS SQUARE TOP FEATURING A PERFORATED PATTERN, THE HALLMARK OF THE ENTIRE NET SEATING COLLECTION. AN IDEAL COMBINATION FOR OUTDOOR FURNITURE SOLUTIONS, WHERE STYLE AND WELL-BEING COME TOGETHER.





NET RELAX salice / sardinia _ NET TABLE 100 salice



NET BENCH corallo / rosa quarzo _ NET RELAX corallo / rosa quarzo
NET TABLE 100 corallo





DOGA RELAX antracite / fumo Sunbrella® _ DOGA TABLE antracite

DOGA COLLECTION

LEGGEREZZA E FUNZIONALITÀ PER DOGA, COLLEZIONE DI SEDUTE CON TAVOLINO ISPIRATA AL TEMA DELLA DOGA RIVISITATA IN CHIAVE CONTEMPORANEA. L'INEDITO RANGE CROMATICO E IL NATURALE GIOCO DI PIENI E DI VUOTI OFFRONO INTRIGANTI POSSIBILITÀ D'ARREDO ALL'ARIA APERTA.

LIGHTNESS AND FUNCTIONALITY ARE THE HALLMARKS OF DOGA, A COLLECTION OF CHAIRS WITH A LOW TABLE INSPIRED BY A SLATTED DESIGN GIVEN A CONTEMPORARY TWIST. THE INNOVATIVE COLOUR RANGE AND THE NATURAL INTERPLAY OF OPEN AND CLOSED SPACES OFFER FASCINATING OPPORTUNITIES FOR FURNISHING OUTDOOR ENVIRONMENTS.



DOGA RELAX antracite / fumo Sunbrella® _ DOGA TABLE antracite

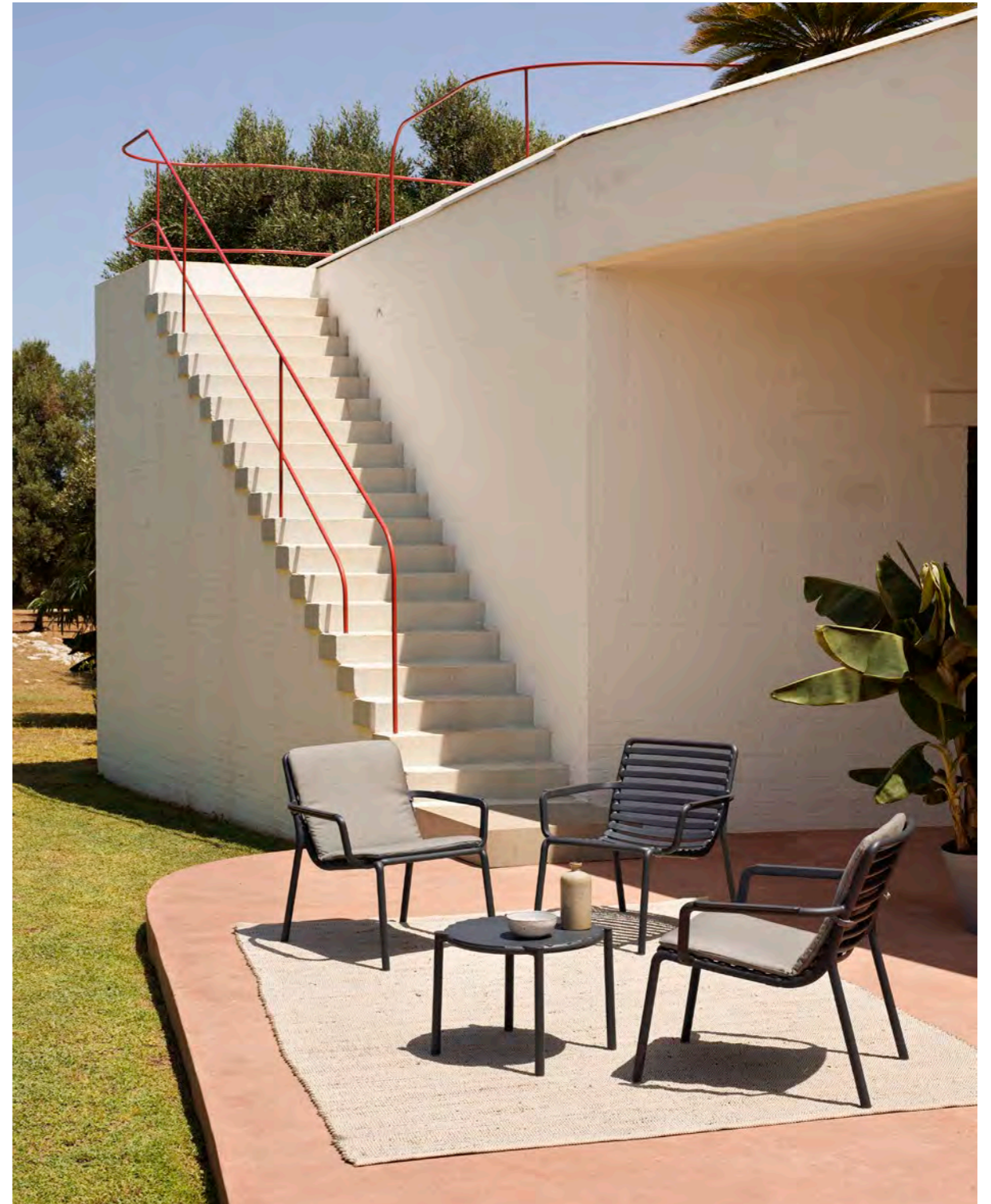



DOGA BISTROT _ DOGA ARMCHAIR _ DOGA RELAX marsala / mattone



DOGA ARMCHAIR pera - marsala - cappuccino



DOGA RELAX cappuccino - agave _ DOGA TABLE agave



FOLIO tortora / lino _ POGGIO tortora



reddot award 2021
winner



archiproducts
DESIGN AWARDS
WINNER 2020

FOLIO COLLECTION

ELEGANTE E AVVOLGENTE ABBRACCIO
STRUTTURALE PER LA POLTRONA RELAX
FOLIO, RECLINABILE IN DUE POSIZIONI E
PROPOSTA CON BASE FISSA O A DONDOLO.

*THE FOLIO RELAXING ARMCHAIR OFFERS AN
ELEGANT AND ENVELOPING STRUCTURAL
EMBRACE, RECLINES TO TWO POSITIONS AND IS
AVAILABLE WITH A FIXED OR ROCKING BASE.*





FOLIO tortora / felce Sunbrella® _ POGGIO tortora

TECHNICAL
DETAILS



regeneration

Nardi produce arredi per l'outdoor studiati per il benessere e il relax delle persone. Lavorare al fine di rendere i processi sempre più sostenibili è parte integrante della filosofia dell'azienda che nel 2019 ha inaugurato il programma industriale Regeneration dedicato alla produzione di arredamenti per esterno in plastica post consumo. Nello stesso anno ha introdotto le analisi LCA su diversi prodotti per mettere progressivamente in atto ulteriori azioni per migliorare le proprie performance ambientali.

Come tutta la gamma di arredi, anche quelli del catalogo Regeneration sono realizzati in impianti progettati con tecnologie all'avanguardia dal punto di vista dell'ecosostenibilità. Tutti gli stabilimenti utilizzano esclusivamente energia elettrica 100% green proveniente da fonti rinnovabili certificate insieme a quella generata dal proprio sistema di pannelli fotovoltaici.

Sempre in ottica ecologica, gli imballi di protezione sono in cartone certificato FSC® e polietilene a bassa densità completamente riciclabile, entrambi concepiti per essere ridotti al minimo. Le scafole contenitive di cartone sono composte mediamente dal 75% di fibre riciclate, con l'impiego di amido di mais come collante. Diverse sono, inoltre, le iniziative dell'azienda a favore di un corretto utilizzo e smaltimento degli imballaggi e dei bancali per il trasporto.

Nardi produces outdoor furniture tailored to people's well-being and relaxation. Working to make processes increasingly sustainable is an integral part of the philosophy of our company which, in 2019, launched the Regeneration industrial programme dedicated to producing outdoor furniture in post-consumer plastic. In the same year, Nardi introduced LCA analysis on several products to gradually implement further actions to improve its environmental performance.

Like the entire range, the furniture in the Regeneration catalogue is made in production plants designed with state-of-the-art technology based on eco-sustainability. All production plants exclusively use 100% green electricity from certified renewable sources together with electricity generated by their own photovoltaic panel system.

Also in keeping with an eco-friendly perspective, protective packaging is made of FSC®-certified cardboard and fully recyclable low-density polyethylene, which are both designed to be minimised. On average, cardboard boxes are made of 75% recycled fibres, with maize starch used as glue. Several of our company initiatives also support the correct use and disposal of packaging and transport pallets.

For more information visit www.nardioutdoor.com/regeneration

MAXIMO

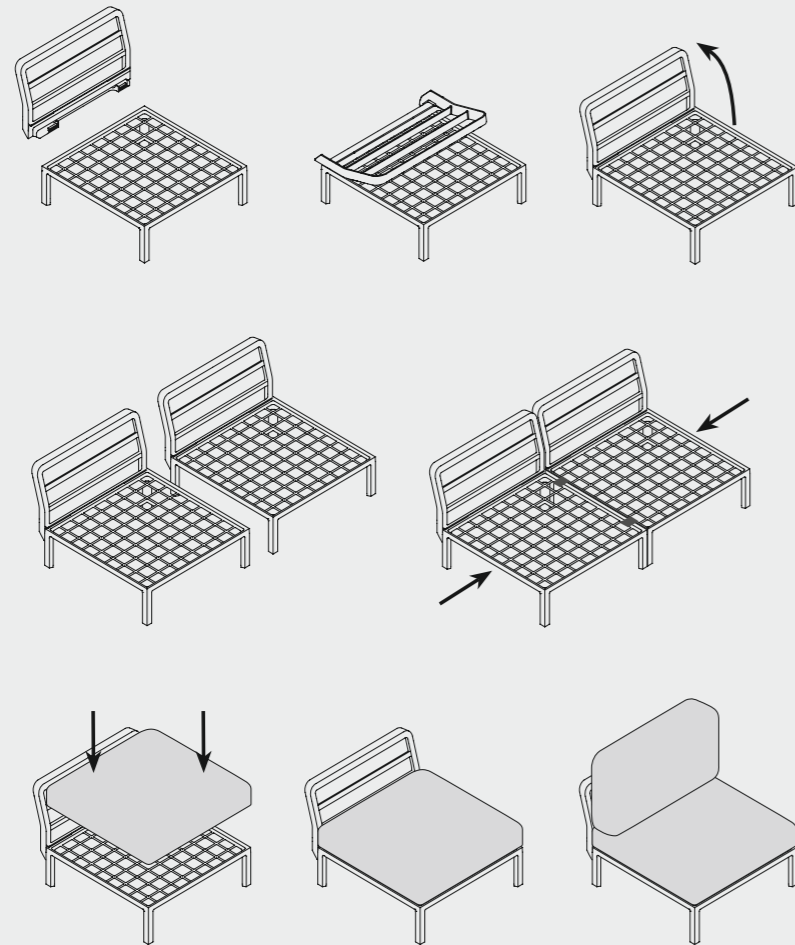

MAXIMO è un sistema modulare di sedute configurabile a piacere. I moduli possono essere fissati tra loro e gli schienali e i braccioli sono agganciabili su tutti i lati della seduta.

Oltre alla versione MAXIMO 5, è possibile configurare e ordinare la tua versione personalizzata elencando tutti i singoli elementi che la formano.

MAXIMO is a modular system of upholstered seats which can be configured to suit your particular needs. The modules can be secured to one another and the backrests and armrests can be attached on all sides of the seat.

In addition to the MAXIMO 5 version, you can configure and order your own customized version simply by listing all the individual elements you require.

MAXIMO POLTRONA

regenerated fiberglass polypropylene
recycled fabric

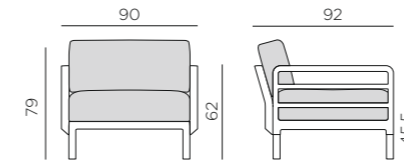

19,2 kg
n. pz. 1



MAXIMO ELEMENTO TERMINALE

regenerated fiberglass polypropylene
recycled fabric

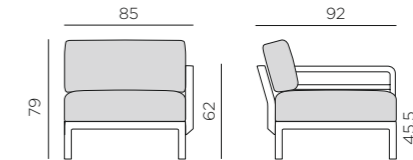

16,9 kg
n. pz. 1



MAXIMO ELEMENTO CENTRALE

regenerated fiberglass polypropylene
recycled fabric

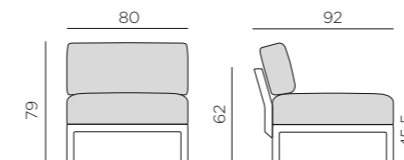

14,6 kg
n. pz. 1



MAXIMO ELEMENTO ANGOLO

regenerated fiberglass polypropylene
recycled fabric

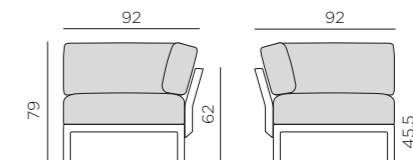

18,4 kg
n. pz. 1



MAXIMO POUF

regenerated fiberglass polypropylene
recycled fabric

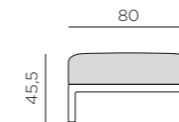

10,7 kg
n. pz. 1



MAXIMO 5

regenerated fiberglass polypropylene
recycled fabric

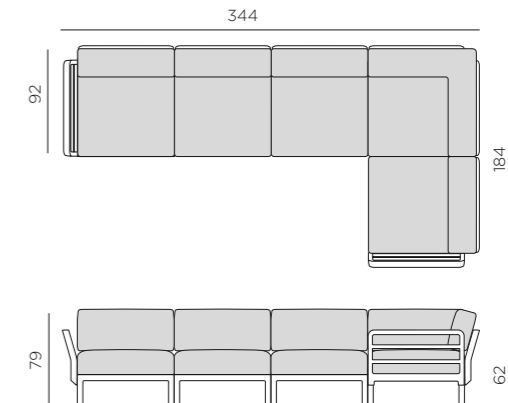

80 kg
n. pz. 1

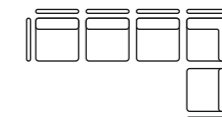

Maximo 5 è composto da 5 sedute e 8 schienali
Maximo 5 consists of 5 seats and 8 backrests



		POLTRONA	ELEMENTO TERMINALE	ELEMENTO CENTRALE	ELEMENTO ANGOLO	POUF	MAXIMO 5
TERRA cannella Sunbrella®		40181.44.219	40182.44.219	40183.44.219	40184.44.219	40179.44.219	40180.44.219
GESSO cannella Sunbrella®		40181.29.219	40182.29.219	40183.29.219	40184.29.219	40179.29.219	40180.29.219
CACTUS cannella Sunbrella®		40181.27.219	40182.27.219	40183.27.219	40184.27.219	40179.27.219	40180.27.219
BASALTO cannella Sunbrella®		40181.25.219	40182.25.219	40183.25.219	40184.25.219	40179.25.219	40180.25.219
TERRA perla Sunbrella®		40181.44.213	40182.44.213	40183.44.213	40184.44.213	40179.44.213	40180.44.213
GESSO perla Sunbrella®		40181.29.213	40182.29.213	40183.29.213	40184.29.213	40179.29.213	40180.29.213
CACTUS perla Sunbrella®		40181.27.213	40182.27.213	40183.27.213	40184.27.213	40179.27.213	40180.27.213
BASALTO perla Sunbrella®		40181.25.213	40182.25.213	40183.25.213	40184.25.213	40179.25.213	40180.25.213



		POLTRONA	ELEMENTO TERMINALE	ELEMENTO CENTRALE	ELEMENTO ANGOLO	POUF	MAXIMO 5
TERRA timo Sunbrella®		40181.44.217	40182.44.217	40183.44.217	40184.44.217	40179.44.217	40180.44.217
GESSO timo Sunbrella®		40181.29.217	40182.29.217	40183.29.217	40184.29.217	40179.29.217	40180.29.217
CACTUS timo Sunbrella®		40181.27.217	40182.27.217	40183.27.217	40184.27.217	40179.27.217	40180.27.217
BASALTO timo Sunbrella®		40181.25.217	40182.25.217	40183.25.217	40184.25.217	40179.25.217	40180.25.217
TERRA lava Sunbrella®		40181.44.215	40182.44.215	40183.44.215	40184.44.215	40179.44.215	40180.44.215
GESSO lava Sunbrella®		40181.29.215	40182.29.215	40183.29.215	40184.29.215	40179.29.215	40180.29.215
CACTUS lava Sunbrella®		40181.27.215	40182.27.215	40183.27.215	40184.27.215	40179.27.215	40180.27.215
BASALTO lava Sunbrella®		40181.25.215	40182.25.215	40183.25.215	40184.25.215	40179.25.215	40180.25.215

Il polipropilene fiberglass rigenerato e il tessuto rigenerato Sunbrella possono presentare delle variazioni di colore dovute all'utilizzo di materiale riciclato - Regenerated fiberglass polypropylene and Sunbrella regenerated fabric may vary in color due to the use of recycled material - Polypropylène fiberglass régénéré et le tissu régénéré Sunbrella peuvent présenter variations de couleur en raison de l'utilisation de matériaux recyclés - Regeneriertem fiberglass-Polypropylen und das regenerierte Gewebe Sunbrella können aufgrund der Verwendung von recyceltem Material Farbunterschiede aufweisen - El polipropileno fiberglass regenerado y el tejido regenerado Sunbrella pueden presentar variaciones de color debido al uso de material reciclado - O polipropileno fiberglass regenerado e o tecido regenerado Sunbrella podem apresentar variações de cor devido ao uso de material reciclado - Polipropilen fiberglass ve Sunbrella rejenere kumaş, geri dönüştürülmüş malzeme kullanımı nedeniyle renk farklılıkları gösterebilir - цвет регенерированного полипропиленового стекловолокна и регенерированной ткани Sunbrella может иметь отличия вследствие использования переработанного материала

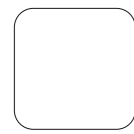

new

recycled Sunbrella® EXTRA
p.175

Tessuti disponibili su ordinazione per minimi quantitativi d'ordine - Fabrics available to order for minimum order quantities - Tissus disponibles sur commande de quantités minimales - Gewebe auf Bestellung für Mindestbestellmengen erhältlich - Telas disponibles bajo pedido para cantidades mínimas - Tecidos disponíveis por encomenda para quantidades mínimas de encomenda - Minimum sipariş miktarına göre sipari verilebilecek mevcut kumaşlar - ткани на заказ для минимального объема заказа.

MAXIMO TAVOLINO 80

regenereted fiberglass polypropylene

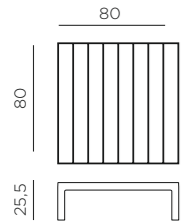

11,8 kg
n. pz. 1

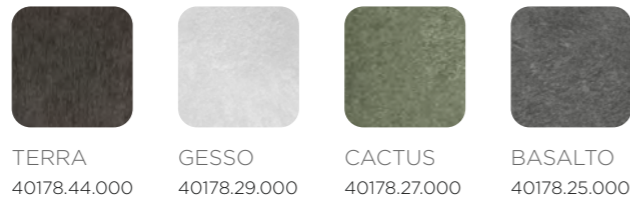

TERRA 40178.44.000
GESSO 40178.29.000
CACTUS 40178.27.000
BASALTO 40178.25.000

MAXIMO TAVOLINO 70 MAXI new

regenereted fiberglass polypropylene

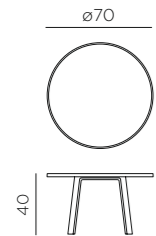

6,7 kg
n. pz. 1

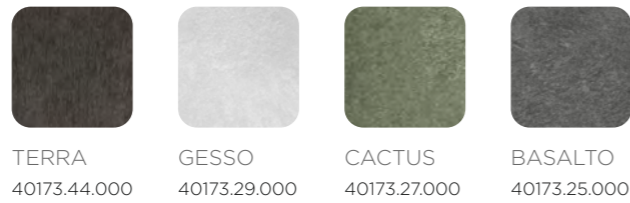

TERRA 40173.44.000
GESSO 40173.29.000
CACTUS 40173.27.000
BASALTO 40173.25.000

MAXIMO TAVOLINO 70 MINI new

regenereted fiberglass polypropylene

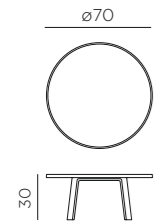

6,4 kg
n. pz. 1

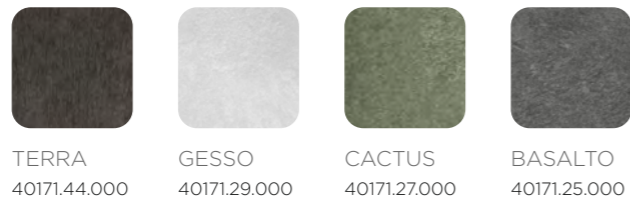

TERRA 40171.44.000
GESSO 40171.29.000
CACTUS 40171.27.000
BASALTO 40171.25.000

MAXIMO TAVOLINO 60 MAXI new

regenereted fiberglass polypropylene

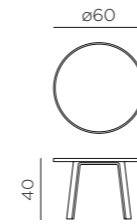

4,7 kg
n. pz. 1

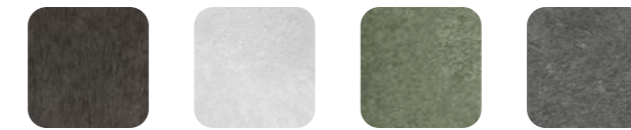

TERRA 40172.44.000
GESSO 40172.29.000
CACTUS 40172.27.000
BASALTO 40172.25.000

MAXIMO TAVOLINO 60 MINI new

regenereted fiberglass polypropylene



4,4 kg
n. pz. 1

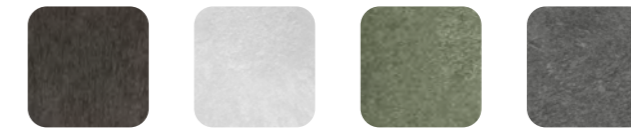

TERRA 40170.44.000
GESSO 40170.29.000
CACTUS 40170.27.000
BASALTO 40170.25.000

MAXIMO TAVOLINO 33 new

regenereted fiberglass polypropylene

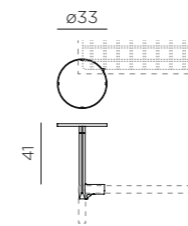

1,3 kg
n. pz. 1

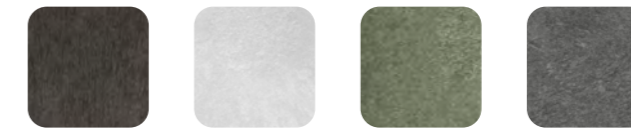

TERRA 40177.44.000
GESSO 40177.29.000
CACTUS 40177.27.000
BASALTO 40177.25.000

MAXIMO PORTAOGGETTI

regenereted fiberglass polypropylene

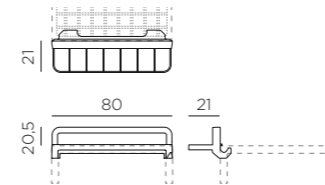

2,3 kg
n. pz. 1

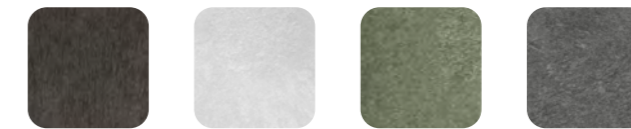

TERRA 40188.44.000
GESSO 40188.29.000
CACTUS 40188.27.000
BASALTO 40188.25.000

Il polipropilene fiberglass rigenerato e il tessuto rigenerato Sunbrella possono presentare delle variazioni di colore dovute all'utilizzo di materiale riciclato - Regenerated fiberglass polypropylene and Sunbrella regenerated fabric may vary in color due to the use of recycled material - Polypropylène fiberglass régénéré et le tissu régénéré Sunbrella peuvent présenter variations de couleur en raison de l'utilisation de matériaux recyclés - Regeneriertem fiberglass-Polypropylen und das regenerierte Gewebe Sunbrella können aufgrund der Verwendung von recyceltem Material Farbunterschiede aufweisen - El polipropileno fiberglass regenerado y el tejido regenerado Sunbrella pueden presentar variaciones de color debido al uso de material reciclado - O polipropileno fiberglass regenerado e o tecido regenerado Sunbrella podem apresentar variações de cor devido ao uso de material reciclado - Polipropilen fiberglass ve Sunbrella rejenere kumaş, geri dönüştürülmüş malzeme kullanımı nedeniyle renk farklılıkları gösterebilir - цвет регенерированного полипропиленового стекловолокна и регенерированной ткани Sunbrella может иметь отличия вследствие использования переработанного материала

MAXIMO BRACCIOLO

regenereted fiberglass polypropylene

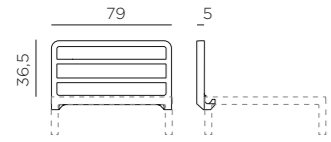

2,4 kg
n. pz. 2



TERRA
40185.44.000



GESSO
40185.29.000

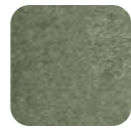

CACTUS
40185.27.000

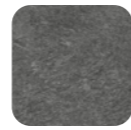

BASALTO
40185.25.000

MAXIMO SCHIENALE

regenereted fiberglass polypropylene

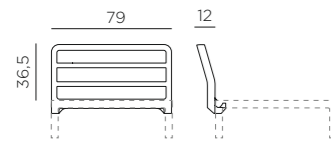

2,5 kg
n. pz. 4



TERRA
40186.44.000



GESSO
40186.29.000

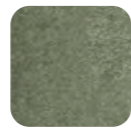

CACTUS
40186.27.000

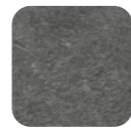

BASALTO
40186.25.000

CUSCINO SCHIENALE MAXIMO

recycled fabric

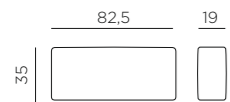

1,4 kg
n. pz. 1



cannella
Sunbrella®
36180.52.219

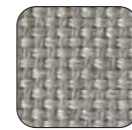

perla
Sunbrella®
36180.52.213



timo
Sunbrella®
36180.52.217



lava
Sunbrella®
36180.52.215

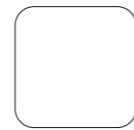

recycled Sunbrella®
EXTRA ▲
p. 175

CUSCINO SCHIENALE ANGOLO MAXIMO

recycled fabric

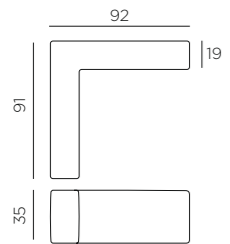

2,8 kg
n. pz. 1



cannella
Sunbrella®
36180.54.219



perla
Sunbrella®
36180.54.213



timo
Sunbrella®
36180.54.217



lava
Sunbrella®
36180.54.215



recycled Sunbrella®
EXTRA ▲
p. 175

CUSCINO ARREDO MAXIMO 50X50

recycled fabric

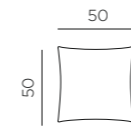

0,8 kg
n. pz. 4



cannella arredo
Sunbrella®
36180.01.220



perla arredo
Sunbrella®
36180.01.214



timo arredo
Sunbrella®
36180.01.218



lava arredo
Sunbrella®
36180.01.216

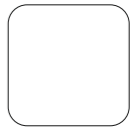

recycled Sunbrella®
EXTRA ▲
p. 175

CUSCINO ARREDO MAXIMO 60X40

recycled fabric

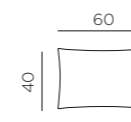

0,9 kg
n. pz. 4



cannella arredo
Sunbrella®
36180.02.220



perla arredo
Sunbrella®
36180.02.214



timo arredo
Sunbrella®
36180.02.218



lava arredo
Sunbrella®
36180.02.216

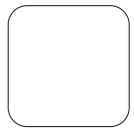

recycled Sunbrella®
EXTRA ▲
p. 175

CUSCINO ARREDO MAXIMO 70X30

recycled fabric

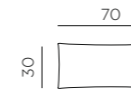

0,7 kg
n. pz. 4



cannella arredo
Sunbrella®
36180.03.220



perla arredo
Sunbrella®
36180.03.214



timo arredo
Sunbrella®
36180.03.218



lava arredo
Sunbrella®
36180.03.216

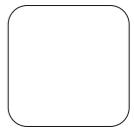

recycled Sunbrella®
EXTRA ▲
p. 175

▲ recycled Sunbrella® EXTRA - p. 175

Tessuti disponibili su ordinazione per minimi quantitativi d'ordine - Fabrics available to order for minimum order quantities - Tissus disponibles sur commande de quantités minimales - Gewebe auf Bestellung für Mindestbestellmengen erhältlich - Telas disponibles bajo pedido para cantidades mínimas - Tecidos disponíveis por encomenda para quantidades mínimas de encomenda - Minimum sipariş miktarına göre sipari verilebilecek mevcut kumaşlar - ткани на заказ для минимального объема заказа

Il polipropilene fiberglass rigenerato e il tessuto rigenerato Sunbrella possono presentare delle variazioni di colore dovute all'utilizzo di materiale riciclato - Regenerated fiberglass polypropylene and Sunbrella regenerated fabric may vary in color due to the use of recycled material - Polypropylène fiberglass régénéré et le tissu régénéré Sunbrella peuvent présenter variations de couleur en raison de l'utilisation de matériaux recyclés - Regeneriertem fiberglass-Polypropylen und das regenerierte Gewebe Sunbrella können aufgrund der Verwendung von recyceltem Material Farbunterschiede aufweisen - El polipropileno fiberglass regenerado y el tejido regenerado Sunbrella pueden presentar variaciones de color debido al uso de material reciclado - O polipropileno fiberglass regenerado e o tecido regenerado Sunbrella podem apresentar variações de cor devido ao uso de material reciclado - Polipropilen fiberglass ve Sunbrella tejener kumaş, geri dönüştürülmüş malzeme kullanımı nedeniyle renk farklılıkları gösterebilir - цвет регенерированного полипропиленового стекловолокна и регенерированной ткани Sunbrella может иметь отличия вследствие использования переработанного материала

KOMODO

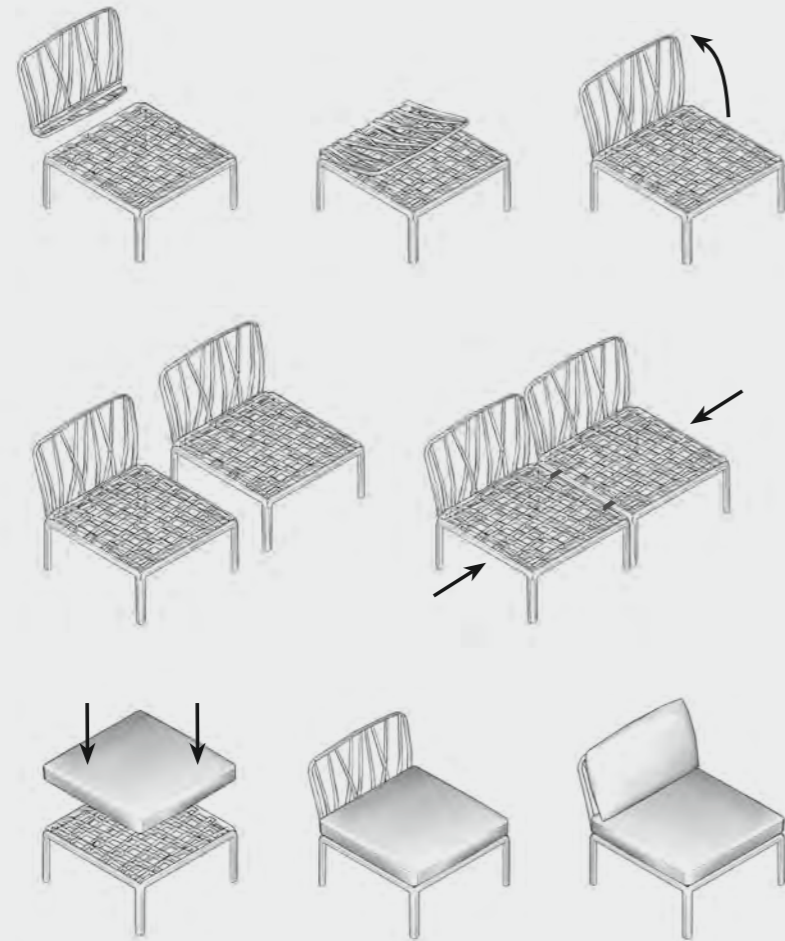

KOMODO è un sistema modulare di sedute configurabile a piacere. I moduli possono essere fissati tra loro e gli schienali e i braccioli sono agganciabili su tutti i lati della seduta. Oltre alla versione KOMODO 5, è possibile configurare e ordinare la tua versione personalizzata elencando tutti i singoli elementi che la formano.

KOMODO is a modular system of upholstered seats which can be configured to suit your particular needs. The modules can be secured to one another and the backrests and armrests can be attached on all sides of the seat. In addition to the KOMODO 5 version, you can configure and order your own customized version simply by listing all the individual elements you require.

KOMODO POLTRONA

fiberglass polypropylene fabric

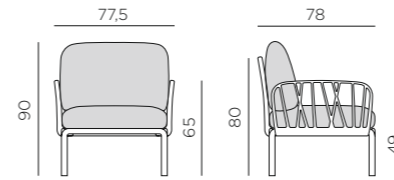

14,3 kg
n. pz. 1



KOMODO ELEMENTO TERMINALE DX/SX

fiberglass polypropylene fabric

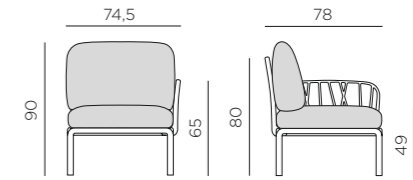

12,6 kg
n. pz. 1



KOMODO ELEMENTO CENTRALE

fiberglass polypropylene fabric

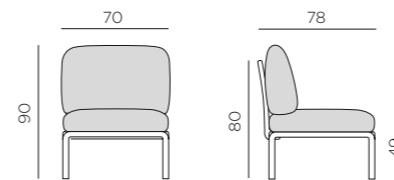

10,9 kg
n. pz. 1



KOMODO ELEMENTO ANGOLO

fiberglass polypropylene fabric

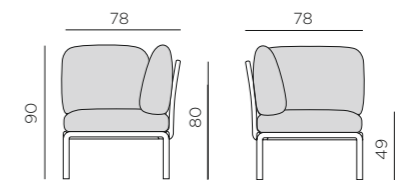

14 kg
n. pz. 1



KOMODO POUF

fiberglass polypropylene fabric

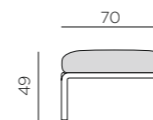

7,5 kg
n. pz. 1



KOMODO 5

fiberglass polypropylene fabric

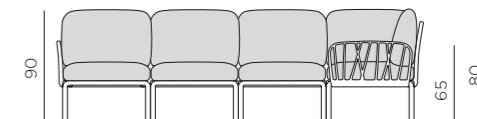
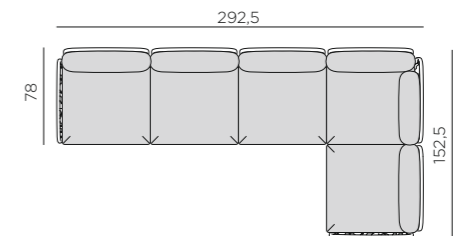

60,3 - 67,3 kg
n. pz. 1



Life Cycle Assessment

For more information visit: www.nardioutdoor.com/sustainability



BIANCO rosa quarzo #		40371.00.066	40372.00.066	40373.00.066	40374.00.066	40369.00.066	40370.00.066
ANTRACITE rosa quarzo #		40371.02.066	40372.02.066	40373.02.066	40374.02.066	40369.02.066	40370.02.066
TORTORA rosa quarzo #		40371.10.066	40372.10.066	40373.10.066	40374.10.066	40369.10.066	40370.10.066
AGAVE rosa quarzo #		40371.16.066	40372.16.066	40373.16.066	40374.16.066	40369.16.066	40370.16.066

BIANCO grigio Komodo		40371.00.172	40372.00.172	40373.00.172	40374.00.172	40369.00.172	40370.00.172
ANTRACITE grigio Komodo		40371.02.172	40372.02.172	40373.02.172	40374.02.172	40369.02.172	40370.02.172
TORTORA grigio Komodo		40371.10.172	40372.10.172	40373.10.172	40374.10.172	40369.10.172	40370.10.172
AGAVE grigio Komodo		40371.16.172	40372.16.172	40373.16.172	40374.16.172	40369.16.172	40370.16.172



BIANCO adriatic Sunbrella® *		40371.00.142	40372.00.142	40373.00.142	40374.00.142	40369.00.142	40370.00.142
ANTRACITE adriatic Sunbrella® *		40371.02.142	40372.02.142	40373.02.142	40374.02.142	40369.02.142	40370.02.142
TORTORA adriatic Sunbrella® *		40371.10.142	40372.10.142	40373.10.142	40374.10.142	40369.10.142	40370.10.142
AGAVE adriatic Sunbrella® *		40371.16.142	40372.16.142	40373.16.142	40374.16.142	40369.16.142	40370.16.142

BIANCO ghiaccio Sunbrella® *		40371.00.138	40372.00.138	40373.00.138	40374.00.138	40369.00.138	40370.00.138
ANTRACITE ghiaccio Sunbrella® *		40371.02.138	40372.02.138	40373.02.138	40374.02.138	40369.02.138	40370.02.138
TORTORA ghiaccio Sunbrella® *		40371.10.138	40372.10.138	40373.10.138	40374.10.138	40369.10.138	40370.10.138
AGAVE ghiaccio Sunbrella® *		40371.16.138	40372.16.138	40373.16.138	40374.16.138	40369.16.138	40370.16.138

Variazioni di colore sono da ritenersi standard e naturali nei tessuti acrilici tinto filo. Posizionare in zone d'ombra - Colour variations are to be considered standard and natural in yarn-dyed acrylic fabrics. Position in shaded areas - Les variations de couleur des tissus acryliques au fil teint sont standard et naturelles. Placer dans des zones ombragées - Farbveränderungen sind als Standard und in im Garn gefärbten Acrylgeweben als natürlich zu betrachten. In schattigen Bereichen aufstellen - Las variaciones de color son normales y naturales en las telas acrílicas teñidas en hilo. Colocar en zonas de sombra - As variações de cor são consideradas standard e naturais nos tecidos acrílico tingidos com fio. Posicionar em zonas de sombra - Boyalı akrilik iplik kumaşlarda renk değişiklikleri standart ve doğal kabul edilir. Gölge alanlara yerleştiriniz - Изменения цвета следует считать нормой, они являются естественными в случае акриловых тканей с окрашенными волокнами. Размещать в тени



	POLTRONA	ELEMENTO TERMINALE DX/SX	ELEMENTO CENTRALE	ELEMENTO ANGOLO	POUF	KOMODO 5
BIANCO avocado Sunbrella® *	40371.00.139	40372.00.139	40373.00.139	40374.00.139	40369.00.139	40370.00.139
ANTRACITE avocado Sunbrella® *	40371.02.139	40372.02.139	40373.02.139	40374.02.139	40369.02.139	40370.02.139
TORTORA avocado Sunbrella® *	40371.10.139	40372.10.139	40373.10.139	40374.10.139	40369.10.139	40370.10.139
AGAVE avocado Sunbrella® *	40371.16.139	40372.16.139	40373.16.139	40374.16.139	40369.16.139	40370.16.139

BIANCO giungla Sunbrella® *	40371.00.140	40372.00.140	40373.00.140	40374.00.140	40369.00.140	40370.00.140
ANTRACITE giungla Sunbrella® *	40371.02.140	40372.02.140	40373.02.140	40374.02.140	40369.02.140	40370.02.140
TORTORA giungla Sunbrella® *	40371.10.140	40372.10.140	40373.10.140	40374.10.140	40369.10.140	40370.10.140
AGAVE giungla Sunbrella® *	40371.16.140	40372.16.140	40373.16.140	40374.16.140	40369.16.140	40370.16.140

Il tessuto rigenerato Sunbrella può presentare delle variazioni di colore dovute all'utilizzo di materiale riciclato - The Sunbrella regenerated fabric may vary in color due to the use of recycled material - Le tissu régénéré Sunbrella peut présenter variations de couleur en raison de l'utilisation de matériaux recyclés - Das regenerierte Gewebe Sunbrella kann aufgrund der Verwendung von recyceltem Material Farbunterschiede aufweisen - El tejido regenerado Sunbrella puede presentar variaciones de color debido al uso de material reciclado - O tecido regenerado Sunbrella pode apresentar variações de cor devido ao uso de material reciclado - Sunbrella rejenere kumaş, geri dönüştürülmüş malzeme kullanımı nedeniyle renk farklılıkları gösterebilir - цвет регенерированной ткани Sunbrella может иметь отличия вследствие использования переработанного материала



	POLTRONA	ELEMENTO TERMINALE DX/SX	ELEMENTO CENTRALE	ELEMENTO ANGOLO	POUF	KOMODO 5
BIANCO canvas Sunbrella® *	40371.00.141	40372.00.141	40373.00.141	40374.00.141	40369.00.141	40370.00.141
ANTRACITE canvas Sunbrella® *	40371.02.141	40372.02.141	40373.02.141	40374.02.141	40369.02.141	40370.02.141
TORTORA canvas Sunbrella® *	40371.10.141	40372.10.141	40373.10.141	40374.10.141	40369.10.141	40370.10.141
AGAVE canvas Sunbrella® *	40371.16.141	40372.16.141	40373.16.141	40374.16.141	40369.16.141	40370.16.141

BIANCO TECH panama	40371.00.131	40372.00.131	40373.00.131	40374.00.131	40369.00.131	40370.00.131
ANTRACITE TECH panama	40371.02.131	40372.02.131	40373.02.131	40374.02.131	40369.02.131	40370.02.131
TORTORA TECH panama	40371.10.131	40372.10.131	40373.10.131	40374.10.131	40369.10.131	40370.10.131
AGAVE TECH panama	40371.16.131	40372.16.131	40373.16.131	40374.16.131	40369.16.131	40370.16.131

* Trattamento laminato su richiesta con quantità minima - Laminated finish available on request with a minimum quantity - Traitement laminé sur demande avec une quantité minimum - Laminierte Ausrüstung auf Anfrage mit einer Mindestmenge - Tratamiento laminado bajo pedido con una cantidad mínima - Tratamento laminado sob encomenda com quantidade mínima - Talep üzerine minimum miktarda lamine işlem - Ламинированная обработка по запросу с минимальным количеством

Tessuti disponibili su ordinazione per minimi quantitativi d'ordine - Fabrics available to order for minimum order quantities - Tissus disponibles sur commande de quantités minimales - Gewebe auf Bestellung für Mindestbestellmengen erhältlich - Telas disponibles bajo pedido para cantidades mínimas - Tecidos disponíveis por encomenda para quantidades mínimas de encomenda - Minimum sipariş miktarına göre sipari verilebilecek mevcut kumaşlar - ткани на заказ для минимального объема заказа.

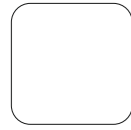

Sunbrella®
+ EXTRA *
p. 172-173

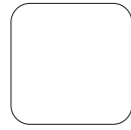

Nardi
Acrylic #
p. 176

Variazioni di colore sono da ritenersi standard e naturali nei tessuti acrilici tinto filo. Posizionare in zone d'ombra - Colour variations are to be considered standard and natural in yarn-dyed acrylic fabrics. Position in shaded areas - Les variations de couleur des tissus acryliques au fil teint sont standard et naturelles. Placer dans des zones ombragées - Farbveränderungen sind als Standard und in im Garn gefärbten Acrylgeweben als natürlich zu betrachten. In schattigen Bereichen aufstellen - Las variaciones de color son normales y naturales en las telas acrílicas teñidas en hilo. Colocar en zonas de sombra - As variações de cor são consideradas standard e naturais nos tecidos acrílico tingidos com fio. Posicionar em zonas de sombra - Boyalı akrilik iplik kumaşlarda renk değişiklikleri standart ve doğal kabul edilir. Gölgeli alanlara yerleştiriniz - Изменения цвета следует считать нормой, они являются естественными в случае акриловых тканей с окрашенными волокнами. Размещать в тени

* Trattamento laminato su richiesta con quantità minima - Laminated finish available on request with a minimum quantity - Traitement laminé sur demande avec une quantité minimum - Laminierter Ausrüstung auf Anfrage mit einer Mindestmenge - Tratamiento laminado bajo pedido con una cantidad mínima - Tratamento laminado sob encomenda com quantidade mínima - Talep üzerine minimum miktarda lamine işlem - Ламинированная обработка по запросу с минимальным количеством

KOMODO OMBRA 3

fiberglass polypropylene / fabric

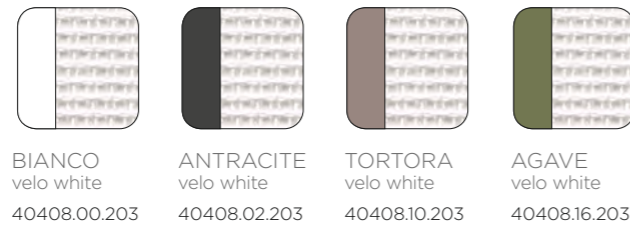
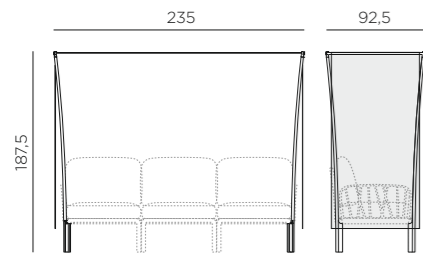

4,7 kg
n. pz. 1

KOMODO OMBRA 2

fiberglass polypropylene / fabric

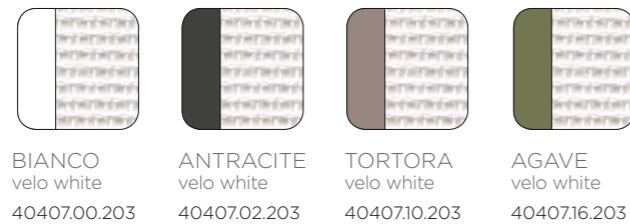
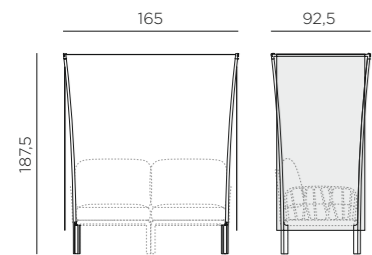

4,6 kg
n. pz. 1

KOMODO TAVOLINO

fiberglass polypropylene

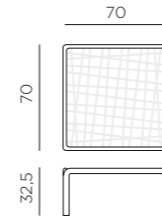

6,7 kg
n. pz. 1 pz. 40



BIANCO 40378.00.000 ANTRACITE 40378.02.000 TORTORA 40378.10.000 AGAVE 40378.16.000

KOMODO TAVOLINO VETRO

fiberglass polypropylene / glass

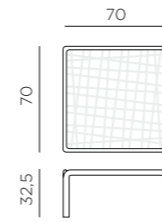

11,4 kg
n. pz. 1 pz. 20



BIANCO vetro 40368.00.501 ANTRACITE vetro 40368.02.501 TORTORA vetro 40368.10.501 AGAVE vetro 40368.16.501

KOMODO BRACCIOLO

fiberglass polypropylene



1,7 kg
n. pz. 2



BIANCO 40375.00.000 ANTRACITE 40375.02.000 TORTORA 40375.10.000 AGAVE 40375.16.000

KOMODO SCHIENALE

fiberglass polypropylene

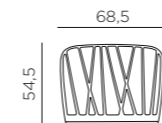

2 kg
n. pz. 4



BIANCO 40376.00.000 ANTRACITE 40376.02.000 TORTORA 40376.10.000 AGAVE 40376.16.000

CUSCINO SCHIENALE KOMODO

fabric

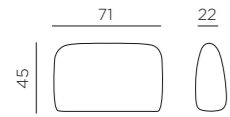

1,4 kg
n. pz. 1

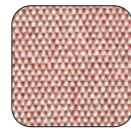

rosa
quarzo #
36370.52.066



grigio
komodo
36370.52.172



adriatic
Sunbrella® *
36370.52.142

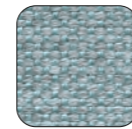

ghiaccio
Sunbrella® *
36370.52.138

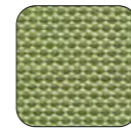

avocado
Sunbrella® *
36370.52.139



giungla
Sunbrella® *
36370.52.140

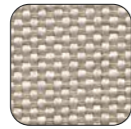

canvas
Sunbrella® *
36370.52.141

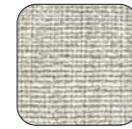

TECH
panama
36370.52.131

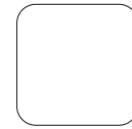

Sunbrella®
+EXTRA ▲
p. 172-173

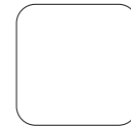

Nardi
Acrylic ▲
p. 176

CUSCINO SCHIENALE ANGOLO KOMODO

fabric

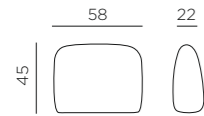

1,1 kg
n. pz. 1

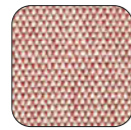

rosa
quarzo #
36370.54.066



grigio
komodo
36370.54.172



adriatic
Sunbrella® *
36370.54.142

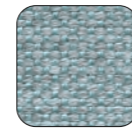

ghiaccio
Sunbrella® *
36370.54.138

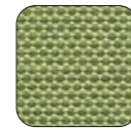

avocado
Sunbrella® *
36370.54.139



giungla
Sunbrella® *
36370.54.140

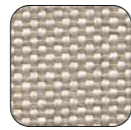

canvas
Sunbrella® *
36370.54.141

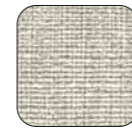

TECH
panama
36370.54.131

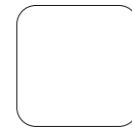

Sunbrella®
+EXTRA ▲
p. 172-173

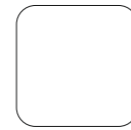

Nardi
Acrylic ▲
p. 176

FOLIO

fiberglass polypropylene

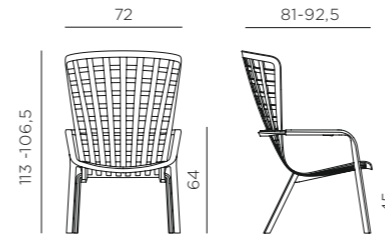

8,2 kg
n. pz. 4

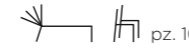

BIANCO
40300.00.000.04



ANTRACITE
40300.02.000.04



TORTORA
40300.10.000.04



AGAVE
40300.16.000.04



TABACCO
40300.53.000.04

KIT FOLIO ROCKING

fiberglass polypropylene

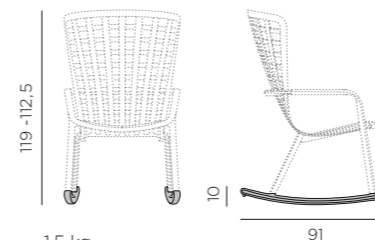

1,5 kg
n. pz. 1

1 KIT= 2 pz

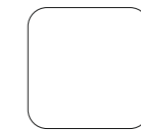

BIANCO
40298.00.000



ANTRACITE
40298.02.000



TORTORA
40298.10.000



AGAVE
40298.16.000



TABACCO
40298.53.000

POGGIO

fiberglass polypropylene

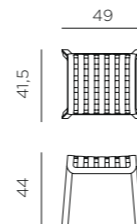

2,7 kg
n. pz. 4



BIANCO
40044.00.000



ANTRACITE
40044.02.000



TORTORA
40044.10.000



AGAVE
40044.16.000



TABACCO
40044.53.000

▲ Sunbrella® e Sunbrella® EXTRA - p. 172-173 Nardi Acrylic - p. 176
Tessuti disponibili su ordinazione per minimi quantitativi d'ordine - Fabrics available to order for minimum order quantities - Tissus disponibles sur commande de quantités minimales - Gewebe auf Bestellung für Mindestbestellmengen erhältlich - Telas disponibles bajo pedido para cantidades mínimas - Tecidos disponíveis por encomenda para quantidades mínimas de encomenda - Minimum sipariş miktarına göre sipari verilebilecek mevcut kumaşlar - ткани на заказ для минимального объема заказа

Variazioni di colore sono da ritenersi standard e naturali nei tessuti acrilici tinto filo. Posizionare in zone d'ombra - Colour variations are to be considered standard and natural in yarn-dyed acrylic fabrics. Position in shaded areas - Les variations de couleur des tissus acryliques au fil teint sont standard et naturelles. Placer dans des zones ombragées - Farbveränderungen sind als Standard und in im Garn gefärbten Acrylgeweben als natürlich zu betrachten. In schattigen Bereichen aufstellen - Las variaciones de color son normales y naturales en las telas acrílicas teñidas en hilo. Colocar en zonas de sombra - As variações de cor são consideradas standard e naturais nos tecidos acrílico tingidos com fio. Posicionar em zonas de sombra - Boyalı akrilik iplik kumaşlarda renk değişiklikleri standart ve doğal kabul edilir. Gölge alanlara yerleştiriniz - Изменения цвета следует считать нормой, они являются естественными в случае акриловых тканей с окрашенными волокнами. Размещать в тени

* Trattamento laminato su richiesta con quantità minima - Laminated finish available on request with a minimum quantity - Traitement laminé sur demande avec une quantité minimum - Laminierte Ausrüstung auf Anfrage mit einer Mindestmenge - Tratamiento laminado bajo pedido con una cantidad mínima - Tratamiento laminado sob encomenda com quantidade mínima - Talep üzerine minimum miktarda lamine işlem - Ламинированная обработка по запросу с минимальным количеством

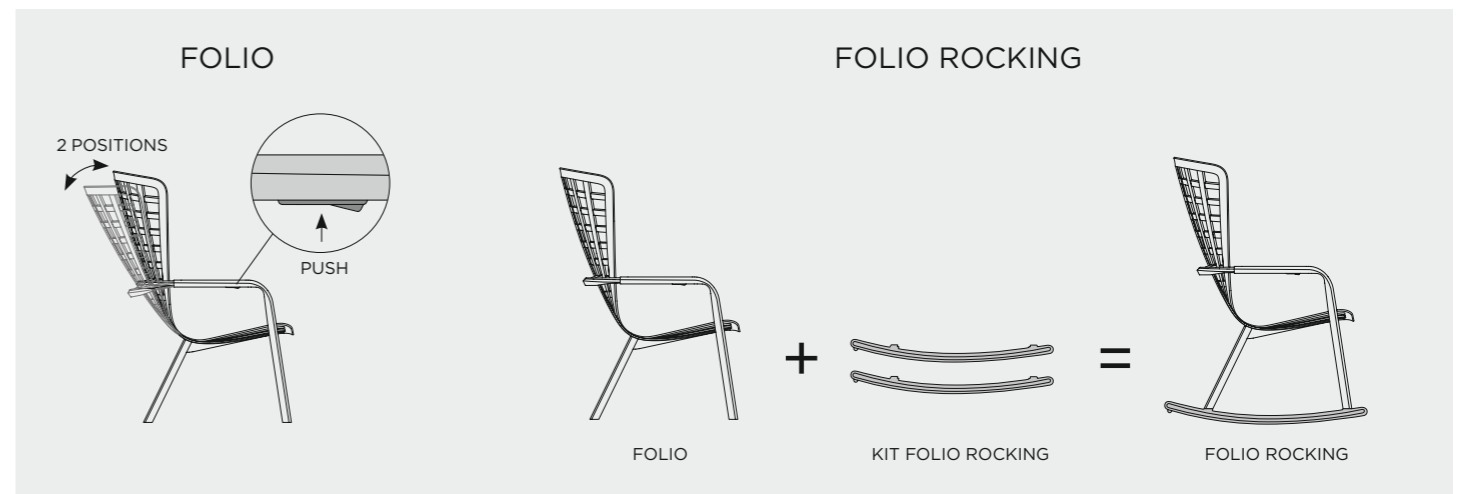

CASSIA ARMCHAIR **new**

regenerated fiberglass polypropylene
fiberglass polypropylene

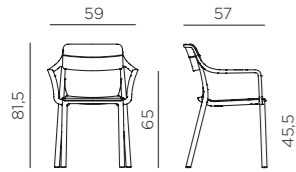

4,2 kg
n. pz. 6



ANTRACITE 40220.02.000
CORDA 40220.24.000
CAPPUCCINO 40220.14.000
TABACCO 40220.53.000
BORGOGNA 40220.38.000
MAYA 40220.42.000



CACTUS 40220.27.000
BASALTO 40220.25.000

CASSIA STOOL **new**

regenerated fiberglass polypropylene
fiberglass polypropylene

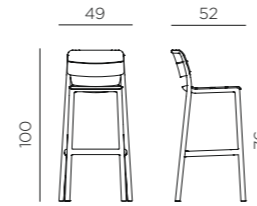

4,6 kg
n. pz. 4



ANTRACITE 40362.02.000
CORDA 40362.24.000
CAPPUCCINO 40362.14.000
TABACCO 40362.53.000
BORGOGNA 40362.38.000
MAYA 40362.42.000



CACTUS 40362.27.000
BASALTO 40362.25.000

CASSIA BISTROT **new**

regenerated fiberglass polypropylene
fiberglass polypropylene

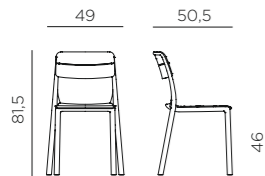

3,7 kg
n. pz. 6



ANTRACITE 40221.02.000
CORDA 40221.24.000
CAPPUCCINO 40221.14.000
TABACCO 40221.53.000
BORGOGNA 40221.38.000
MAYA 40221.42.000



CACTUS 40221.27.000
BASALTO 40221.25.000

TIBERINA ARMCHAIR

regenerated fiberglass polypropylene
fiberglass polypropylene

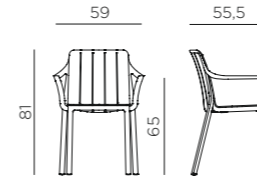

5 kg
n. pz. 6



TERRA 40205.44.000
ANTRACITE 40205.02.000
TORTORA 40205.10.000
CORDA 40205.24.000

TIBERINA BISTROT

regenerated fiberglass polypropylene
fiberglass polypropylene

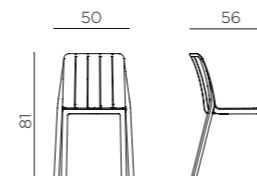

4,6 kg
n. pz. 6



TERRA 40206.44.000
ANTRACITE 40206.02.000
TORTORA 40206.10.000
CORDA 40206.24.000

Il polipropilene fiberglass rigenerato può presentare delle variazioni di colore dovute all'utilizzo di materiale riciclato - Regenerated fiberglass polypropylene may vary in color due to the use of recycled material - Polypropylène fiberglass régénéré peut présenter variations de couleur en raison de l'utilisation de matériaux recyclés - Regeneriertem fiberglass-Polypropylen kann aufgrund der Verwendung von recyceltem Material Farbunterschiede aufweisen - El polipropileno fiberglass regenerado puede presentar variaciones de color debido al uso de material reciclado - O polipropileno fiberglass regenerado pode apresentar variações de cor devido ao uso de material reciclado - Rejenere edilmis polipropilen fiberglass, geri dönüşüm malzemesi kullanımı nedeniyle renk değişikliklerine maruz kalabilir - цвет регенерированного полипропиленового стекловолокна может иметь отличия вследствие использования переработанного материала

DOGA RELAX

fiberglass polypropylene

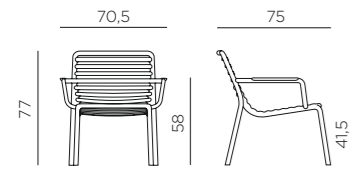

6 kg
n. pz. 4



pz. 12



BIANCO
40256.00.000



ANTRACITE
40256.02.000



CAPPUCCINO
40256.14.000



MENTA
40256.15.000



AGAVE
40256.16.000



PERA
40256.18.000



MARSALA
40256.21.000



TABACCO
40256.53.000

DOGA BISTROT

fiberglass polypropylene

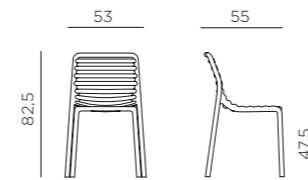

4,1 kg
n. pz. 6



pz. 8



BIANCO
40255.00.000



ANTRACITE
40255.02.000



CAPPUCCINO
40255.14.000



MENTA
40255.15.000



AGAVE
40255.16.000



PERA
40255.18.000



MARSALA
40255.21.000



TABACCO
40255.53.000

DOGA ARMCHAIR

fiberglass polypropylene

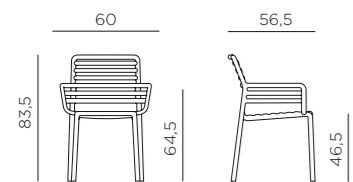

5,1 kg
n. pz. 6



pz. 11



BIANCO
40254.00.000



ANTRACITE
40254.02.000



CAPPUCCINO
40254.14.000



MENTA
40254.15.000



AGAVE
40254.16.000



PERA
40254.18.000



MARSALA
40254.21.000



TABACCO
40254.53.000

DOGA STOOL

fiberglass polypropylene

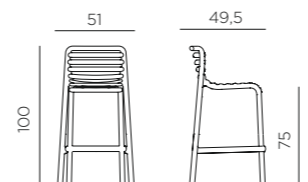

5,1 kg
n. pz. 4



pz. 10



BIANCO
40348.00.000



ANTRACITE
40348.02.000



CAPPUCCINO
40348.14.000



MENTA
40348.15.000



AGAVE
40348.16.000



PERA
40348.18.000



MARSALA
40348.21.000



TABACCO
40348.53.000

NET LOUNGE

fiberglass polypropylene

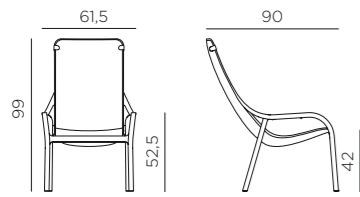

5,3 kg
n. pz. 4 pz. 10



BIANCO 40329.00.000 ANTRACITE 40329.02.000 SALICE 40329.04.000 TORTORA 40329.10.000 SENAPE 40329.56.000 CORALLO 40329.75.000

NET BENCH

fiberglass polypropylene

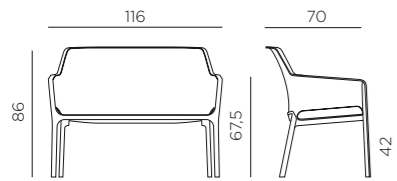

8,9 kg
n. pz. 20 pz. 10



BIANCO 40338.00.000 ANTRACITE 40338.02.000 SALICE 40338.04.000 TORTORA 40338.10.000 SENAPE 40338.56.000 CORALLO 40338.75.000

NET RELAX

fiberglass polypropylene

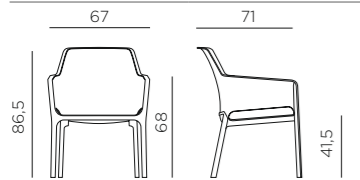

4,9 kg
n. pz. 20 pz. 10



BIANCO 40327.00.000 ANTRACITE 40327.02.000 SALICE 40327.04.000 TORTORA 40327.10.000 SENAPE 40327.56.000 CORALLO 40327.75.000

NET

fiberglass polypropylene

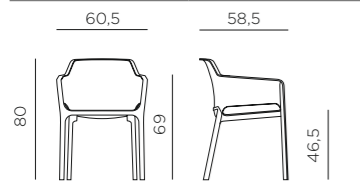

3,9 kg
n. pz. 6 pz. 8



BIANCO 40326.00.000.06 ANTRACITE 40326.02.000.06 SALICE 40326.04.000.06 TORTORA 40326.10.000.06 SENAPE 40326.56.000.06 CORALLO 40326.75.000.06

BIT

fiberglass polypropylene

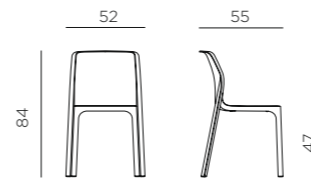

3,5 kg
n. pz. 6 pz. 10



BIANCO 40328.00.000.06 ANTRACITE 40328.02.000.06 SALICE 40328.04.000.06 TORTORA 40328.10.000.06 SENAPE 40328.56.000.06 CORALLO 40328.75.000.06

NET STOOL

fiberglass polypropylene

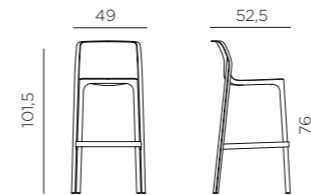

4,4 kg
n. pz. 4 pz. 10



BIANCO 40355.00.000 ANTRACITE 40355.02.000 SALICE 40355.04.000 TORTORA 40355.10.000 SENAPE 40355.56.000 CORALLO 40355.75.000

NET STOOL MINI

fiberglass polypropylene

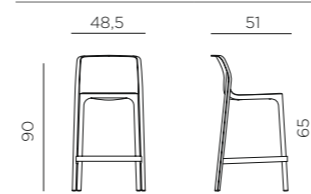

4,2 kg
n. pz. 4 pz. 9



BIANCO 40356.00.000 ANTRACITE 40356.02.000 SALICE 40356.04.000 TORTORA 40356.10.000 SENAPE 40356.56.000 CORALLO 40356.75.000

TRILL ARMCHAIR



fiberglass polypropylene

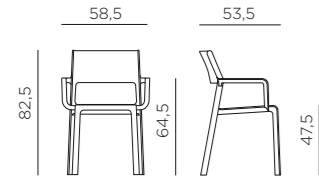

4,7 kg
n. pz. 6



BIANCO 40250.00.000 ANTRACITE 40250.02.000 GRIGIO 40250.03.000 TORTORA 40250.10.000 AGAVE 40250.16.000 OTTANIO 40250.49.000



TABACCO 40250.53.000 SENAPE 40250.56.000

TRILL BISTROT

fiberglass polypropylene

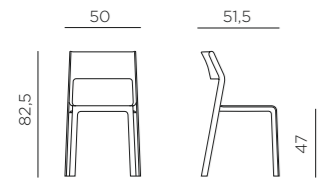

3,8 kg
n. pz. 6



BIANCO 40253.00.000 ANTRACITE 40253.02.000 GRIGIO 40253.03.000 TORTORA 40253.10.000 AGAVE 40253.16.000 OTTANIO 40253.49.000



TABACCO 40253.53.000 SENAPE 40253.56.000

TRILL STOOL

fiberglass polypropylene

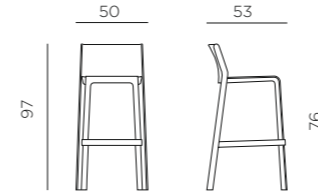

5 kg
n. pz. 4



BIANCO 40350.00.000 ANTRACITE 40350.02.000 GRIGIO 40350.03.000 TORTORA 40350.10.000 AGAVE 40350.16.000 OTTANIO 40350.49.000



TABACCO 40350.53.000 SENAPE 40350.56.000

TRILL STOOL MINI

fiberglass polypropylene

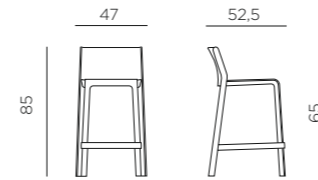

4,6 kg
n. pz. 4



BIANCO 40353.00.000 ANTRACITE 40353.02.000 GRIGIO 40353.03.000 TORTORA 40353.10.000 AGAVE 40353.16.000 OTTANIO 40353.49.000



TABACCO 40353.53.000 SENAPE 40353.56.000

RIO BENCH ALU

aluminium

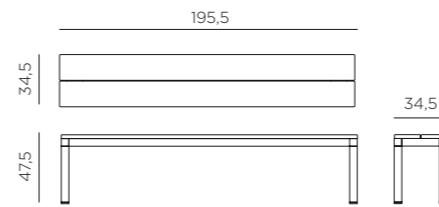

17 kg
n. pz. 1



verniciato bianco
49053.00.000

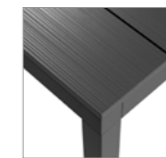

verniciato antracite
49052.02.000



verniciato tortora
49059.10.000



Life Cycle Assessment
For more information visit: www.nardioutdoor.com/sustainability

EPD® dichiarazione ambientale di prodotto/ environmental product declaration

PLANO **new**

fiberglass polypropylene / synthetic fabric

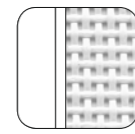
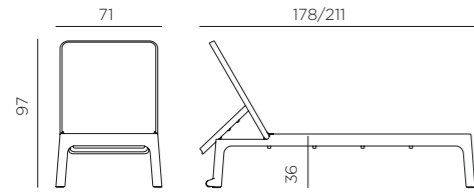

BIANCO
bianco
40462.00.107

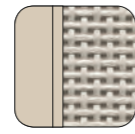

CORDA
incenso
40462.24.210

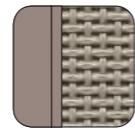

TORTORA
tortora
40462.10.104



TABACCO
castagno
40462.53.211

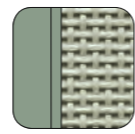

MENTA
mandorla
40462.15.212

14,2 kg
n. pz. 12



Tessuto ricambiabile
Replaceable fabric
Tissu changeable
Auswechselbarer Stoff
Tela sustituible
Tecidos recambiáveis
Değiştirilebilen Kumaş
Съемная ткань

ATLANTICO

fiberglass polypropylene / synthetic fabric

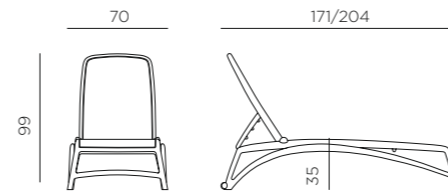

16 kg
n. pz. 20



Tessuto ricambiabile
Replaceable fabric
Tissu changeable
Auswechselbarer Stoff
Tela sustituible
Tecidos recambiáveis
Değiştirilebilen Kumaş
Съемная ткань

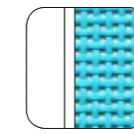

BIANCO
celeste
40450.00.075

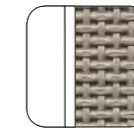

BIANCO
tortora
40450.00.104

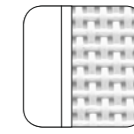

BIANCO
bianco
40450.00.107

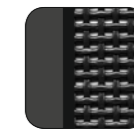

ANTRACITE
antracite
40450.02.057

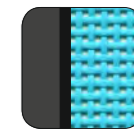

ANTRACITE
celeste
40450.02.075

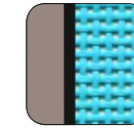

TORTORA
celeste
40450.10.075

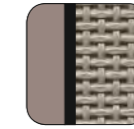

TORTORA
tortora
40450.10.104

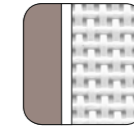

TORTORA
bianco
40450.10.107

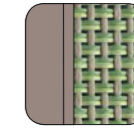

TORTORA
agave
40450.10.101

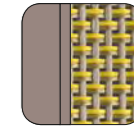

TORTORA
deserto
40450.10.103

BRACCIOLO ATLANTICO

fiberglass polypropylene

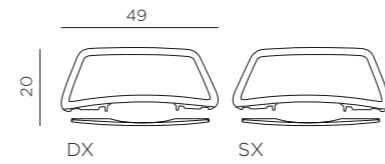

1,1 kg
n. pz. 1

1 KIT = 2 pz (1DX+1SX)



BIANCO
40452.00.000



ANTRACITE
40452.02.000



TORTORA
40452.10.000

TEVERE

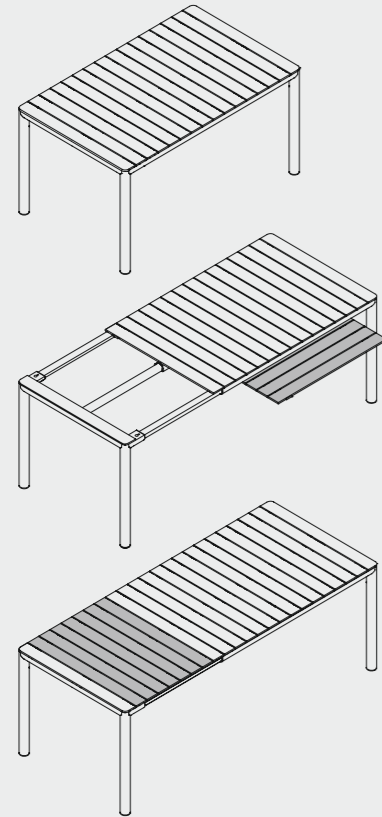

tevere 147 extensible
6/8 147/211x90x76,5 cm

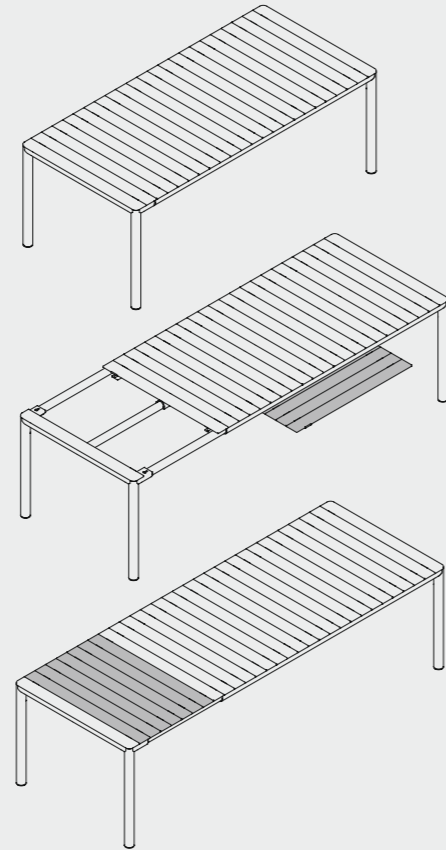

tevere 210 extensible
8/10 211/275x100x76,5 cm

TEVERE 210 EXTENSIBLE 8/10

regenerated fiberglass polypropylene / aluminium
fiberglass polypropylene / aluminium

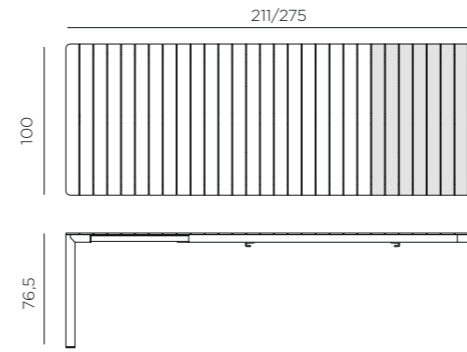

53 kg
n. pz. 1

regenerated



TERRA *
verniciato terra
49668.44.000



ANTRACITE *
verniciato antracite
49652.02.000



TORTORA
verniciato tortora
49659.10.000



CORDA
verniciato corda
49669.24.000

TEVERE 147 EXTENSIBLE 6/8

regenerated fiberglass polypropylene / aluminium
fiberglass polypropylene / aluminium

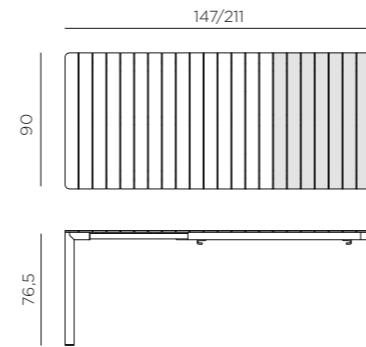

38 kg
n. pz. 1

regenerated



TERRA *
verniciato terra
49468.44.000



ANTRACITE *
verniciato antracite
49452.02.000



TORTORA
verniciato tortora
49459.10.000



CORDA
verniciato corda
49469.24.000

* È consigliabile posizionare in zone d'ombra - It is advisable to position it in the shade. - Il est conseillé de le placer dans des zones ombragées - Das Aufstellen in schattigen Bereichen wird empfohlen - Se aconseja colocar en zonas sombreadas - É aconselhável colocar em áreas sombreadas - Gölge alanlara yerleştirilmesi tavsiye edilir - Рекомендуется устанавливать в тенистых местах

Il polipropilene fiberglass rigenerato può presentare delle variazioni di colore dovute all'utilizzo di materiale riciclato - Regenerated fiberglass polypropylene may vary in color due to the use of recycled material - Polypropylène fiberglass régénéré peut présenter variations de couleur en raison de l'utilisation de matériaux recyclés - Regeneriertem fiberglass-Polypropylen kann aufgrund der Verwendung von recyceltem Material Farbunterschiede aufweisen - El polipropileno fiberglass regenerado puede presentar variaciones de color debido al uso de material reciclado - O polipropileno fiberglass regenerado pode apresentar variações de cor devido ao uso de material reciclado - Rejenere edilmiş polipropilen fiberglass, geri dönüşüm malzemesi kullanımı nedeniyle renk değişikliklerine maruz kalabilir - цвет регенерированного полипропиленового стекловолокна может иметь отличия вследствие использования переработанного материала

RIO

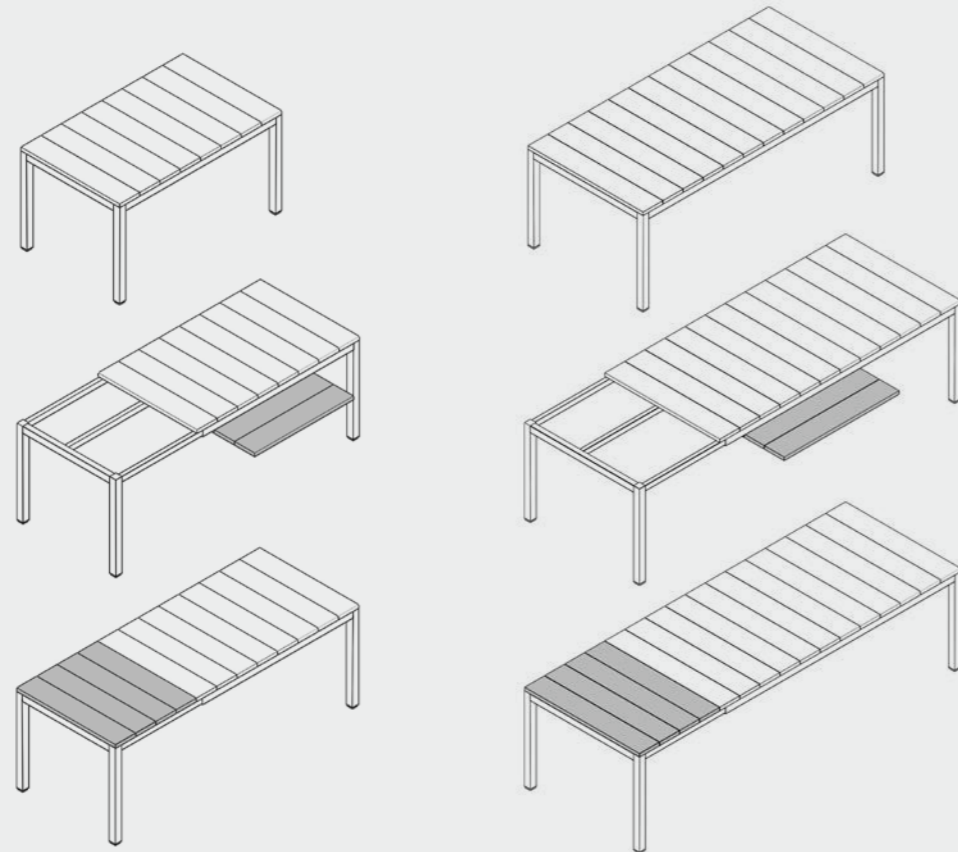

rio 140 extensibile
6/8 140/210x85x76 cm

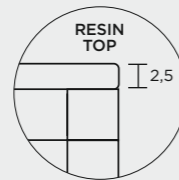

rio 210 extensibile
8/10 210/280x100x76 cm

rio **ALU** 140 extensibile
6/8 140/210x85x75 cm

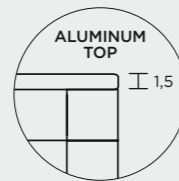

rio **ALU** 210 extensibile
8/10 210/280x100x75 cm

RIO **ALU** 210 EXTENSIBILE 8/10

aluminium

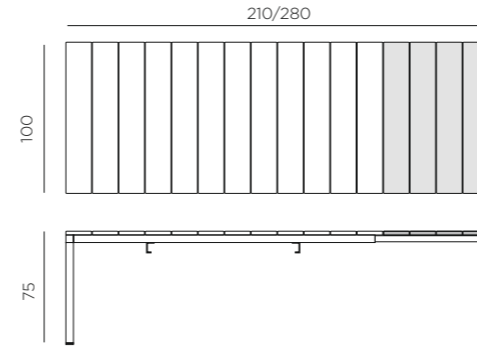

54 kg
n. pz. 1

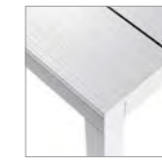

verniciato
bianco
48853.00.000

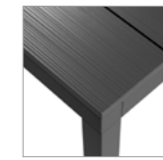

verniciato
antracite *
48852.02.000

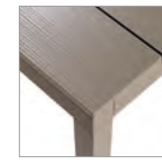

verniciato
tortora
48859.10.000

RIO **ALU** 140 EXTENSIBILE 6/8

aluminium

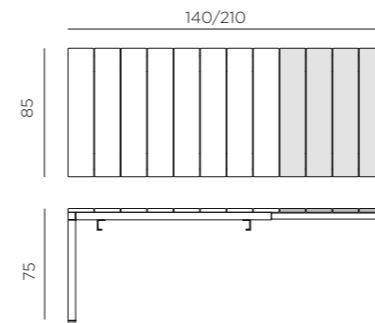

37,1 kg
n. pz. 1

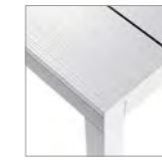

verniciato
bianco
48653.00.000

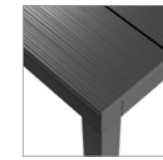

verniciato
antracite *
48652.02.000

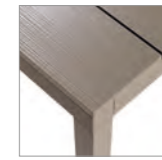

verniciato
tortora
48659.10.000

RIO **ALU** 210 FIX 8

aluminium

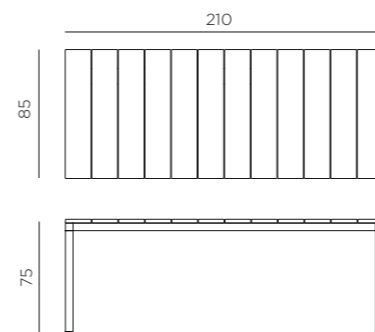

37 kg
n. pz. 1



verniciato
bianco
49153.00.000

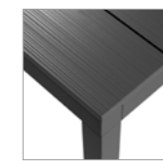

verniciato
antracite *
49152.02.000

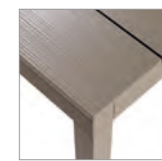

verniciato
tortora
49159.10.000

* È consigliabile posizionare in zone d'ombra - It is advisable to position it in the shade. - Il est conseillé de le placer dans des zones ombragées - Das Aufstellen in schattigen Bereichen wird empfohlen - Se aconseja colocar en zonas sombreadas - É aconselhável colocar em áreas sombreadas - Gölge alanlara yerleştirilmesi tavsiye edilir - Рекомендуется устанавливать в тенистых местах

RIO 210 EXTENSIBLE 8/10

durelTOP / polypropylene / aluminium

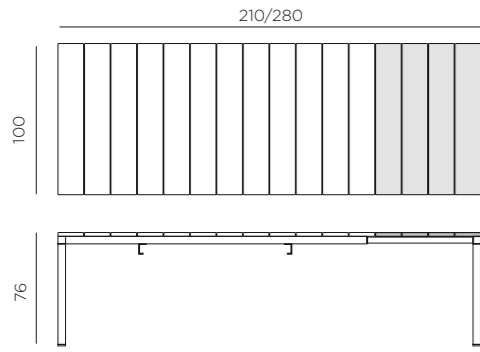

49 kg
n. pz. 1



BIANCO
verniciato bianco
48253.00.000

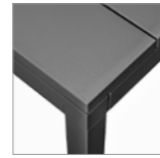

ANTRACITE *
verniciato antracite
48252.02.000

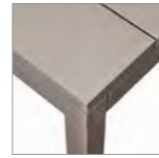

TORTORA
verniciato tortora
48259.10.000

RIO 140 EXTENSIBLE 6/8

durelTOP / polypropylene / aluminium

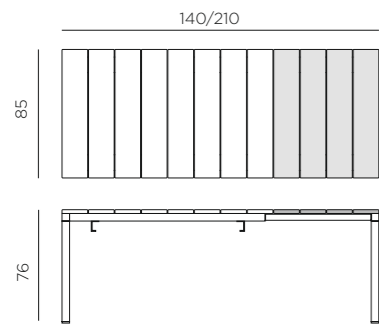

32,6 kg
n. pz. 1



BIANCO
verniciato bianco
48353.00.000

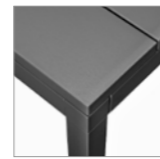

ANTRACITE *
verniciato antracite
48352.02.000

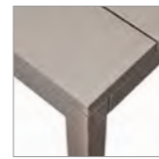

TORTORA
verniciato tortora
48359.10.000

PIAVE 160X90 new

materia laminate hpl / aluminium

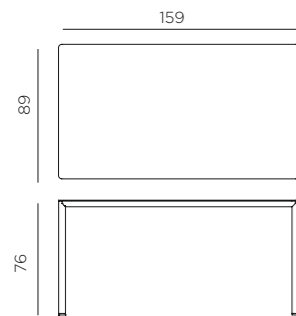

19 kg
n. pz. 1



ANTRACITE
MATERIA *
verniciato antracite
50252.00.352



CORDA
MATERIA
verniciato corda
50269.00.369



TORTORA
MATERIA
verniciato tortora
50259.00.359

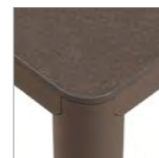

TABACCO
MATERIA *
verniciato tabacco
50267.00.367

CUBE 140X80

durelTOP / polypropylene / aluminium

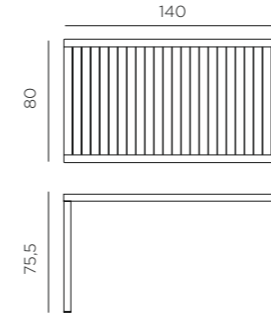

16,9 kg
n. pz. 1



pz. 20



BIANCO
verniciato bianco
47753.00.000



ANTRACITE *
verniciato antracite
47752.02.000



TORTORA
verniciato tortora
47759.10.000



TABACCO *
verniciato tabacco
47767.53.000

CUBE 120X70

durelTOP / polypropylene / aluminium

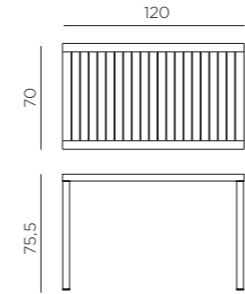

13,3 kg
n. pz. 1



pz. 20



BIANCO
verniciato bianco
47653.00.000



ANTRACITE *
verniciato antracite
47652.02.000



TORTORA
verniciato tortora
47659.10.000



TABACCO *
verniciato tabacco
47667.53.000

CUBE 80

durelTOP / polypropylene / aluminium

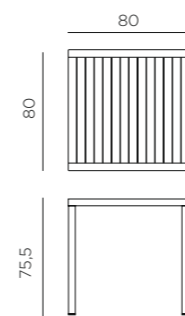

11,5 kg
n. pz. 1



pz. 20



BIANCO
verniciato bianco
48053.00.000



ANTRACITE *
verniciato antracite
48052.02.000



TORTORA
verniciato tortora
48059.10.000



TABACCO *
verniciato tabacco
48067.53.000

Non lasciare sostanze oleose o acide sui piani laminati per evitare possibili residui permanenti - Do not leave oily or acidic substances on laminate tops to avoid possible permanent residue - Ne pas laisser de substances huileuses ou acides sur les plans stratifiés afin d'éviter d'éventuels résidus permanents - Keine öligen oder säurehaltigen Substanzen auf den Laminatflächen hinterlassen, um bleibende Rückstände zu vermeiden - No dejar sustancias aceitosas o ácidas sobre los tableros laminados para evitar posibles residuos permanentes - Não deixar substâncias oleosas ou ácidas sobre os tampos laminados para evitar possíveis resíduos permanentes - Laminat yüzeylerde yağlı veya asidik maddeler bırakmayın, aksi takdirde kalıcı lekeler oluşabilir - Во избежание образования неудаляемых отложений не оставлять маслянистые или кислотные вещества на ламинированных поверхностях

* Posizionare in zone d'ombra - Position in shaded areas - Placer dans des zones ombragées - In schattigen Bereichen aufstellen - Colocar en zonas de sombra - Posicionar em zonas de sombra - Gölge alanlara yerleştiriniz - Размещать в тени

* È consigliabile posizionare in zone d'ombra - It is advisable to position it in the shade. - Il est conseillé de le placer dans des zones ombragées - Das Aufstellen in schattigen Bereichen wird empfohlen - Se aconseja colocar en zonas sombreadas - É aconselhável colocar em áreas sombreadas - Gölge alanlara yerleştirilmesi tavsiye edilir - Рекомендуется устанавливать в тенистых местах

CUBE 70

durelTOP / polypropylene / aluminium

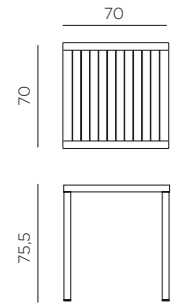

9,5 kg
n. pz. 1  pz. 20



BIANCO
verniciato bianco
47853.00.000

ANTRACITE *
verniciato antracite
47852.02.000

TORTORA
verniciato tortora
47859.10.000

TABACCO *
verniciato tabacco
47867.53.000

SPRITZ

fiberglass polypropylene

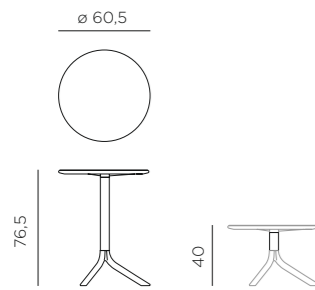

4,3 kg
n. pz. 1



BIANCO
40058.00.000

ANTRACITE
40058.02.000

ROSSO
40058.07.000

TORTORA
40058.10.000

AGAVE
40058.16.000

CELESTE
40058.39.000



new
CORDA
40058.24.000

DOGA TABLE

fiberglass polypropylene

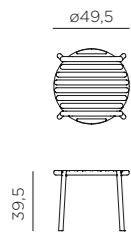

2,9 kg
n. pz. 4  pz. 8



BIANCO
40042.00.000

ANTRACITE
40042.02.000

CAPPUCCINO
40042.14.000

MENTA
40042.15.000

AGAVE
40042.16.000

PERA
40042.18.000



MARSALA
40042.21.000

TABACCO
40042.53.000

NET TABLE 100

fiberglass polypropylene

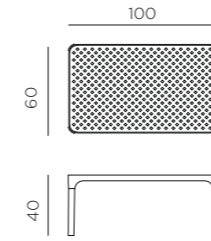

6,3 kg
n. pz. 1



BIANCO
40064.00.000

ANTRACITE
40064.02.000

SALICE
40064.04.000

TORTORA
40064.10.000

SENAPE
40064.56.000

CORALLO
40064.75.000

NET TABLE 40 **new**

fiberglass polypropylene

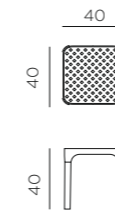

1,7 kg
n. pz. 6  pz. 5



BIANCO
40062.00.000

ANTRACITE
40062.02.000

SALICE
40062.04.000

TORTORA
40062.10.000

SENAPE
40062.56.000

CORALLO
40062.75.000



CORDA
40062.24.000

MENTA
40062.15.000

TABACCO
40062.53.000

POP

fiberglass polypropylene

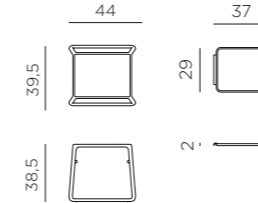

2,5 kg
n. pz. 4  pz. 14



BIANCO
40048.00.000

ANTRACITE
40048.02.000

TORTORA
40048.10.000

* È consigliabile posizionare in zone d'ombra - It is advisable to position it in the shade. - Il est conseillé de le placer dans des zones ombragées - Das Aufstellen in schattigen Bereichen wird empfohlen - Se aconseja colocar en zonas sombreadas - É aconselhável colocar em áreas sombreadas - Gölge alanlara yerleştirilmesi tavsiye edilir - Рекомендуется устанавливать в тенистых местах

SIPARIO 3

regenerated fiberglass polypropylene

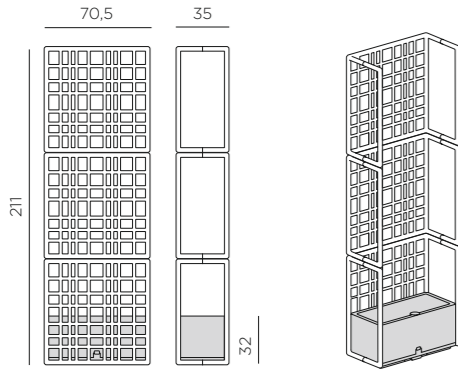

19,1 kg
n. pz. 1

SIPARIO 2



regenerated fiberglass polypropylene

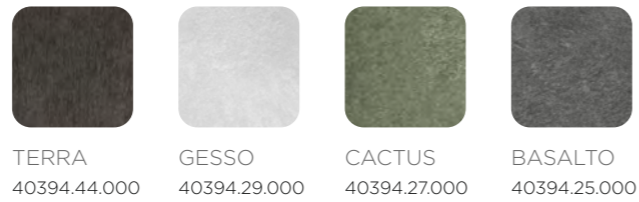
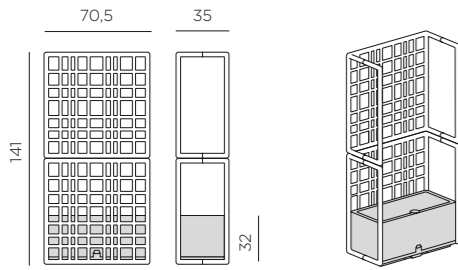

14,6 kg
n. pz. 1

SIPARIO MODULO

regenerated fiberglass polypropylene

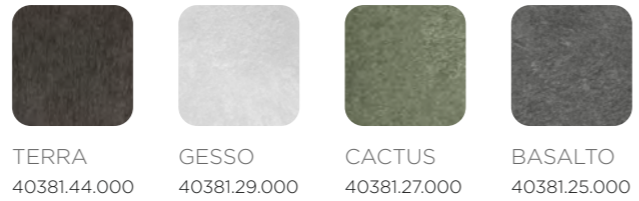
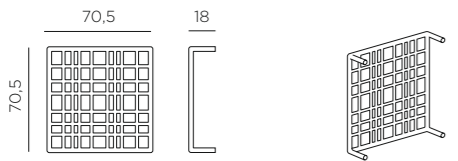

3,3 kg
n. pz. 1

SIPARIO VASO

regenerated fiberglass polypropylene

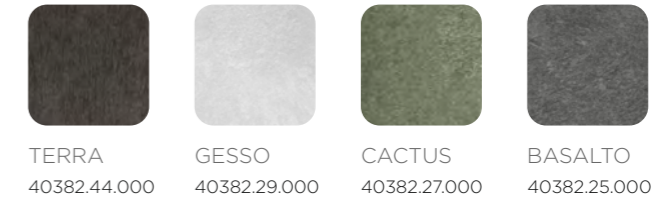
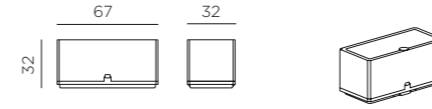

6,4 kg
n. pz. 1

SIPARIO CHIUSURA

regenerated fiberglass polypropylene

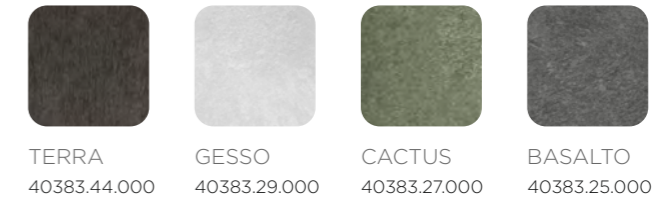
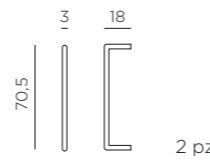

1 kg
n. pz. 1 1 KIT = 2 pz

SIPARIO KIT CLIPS

regenerated fiberglass polypropylene

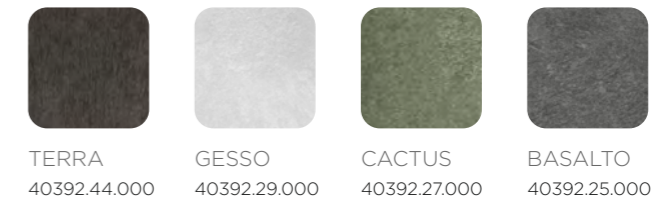
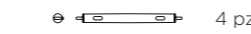

3 6 pz

0,4 kg
n. pz. 1 1 KIT = 4+6 pz



Life Cycle Assessment

For more information visit: www.nardioutdoor.com/sustainability

Il polipropilene fiberglass rigenerato può presentare delle variazioni di colore dovute all'utilizzo di materiale riciclato - Regenerated fiberglass polypropylene may vary in color due to the use of recycled material - Polypropylène fiberglass régénéré peut présenter variations de couleur en raison de l'utilisation de matériaux recyclés - Regeneriertem fiberglass-Polypropylen kann aufgrund der Verwendung von recyceltem Material Farbunterschiede aufweisen - El polipropileno fiberglass regenerado puede presentar variaciones de color debido al uso de material reciclado - O polipropileno fiberglass regenerado pode apresentar variações de cor devido ao uso de material reciclado - Rejenere edilmiş polipropilen fiberglass, geri dönüşüm malzemesi kullanımı nedeniyle renk değişikliklerine maruz kalabilir - цвет регенерированного полипропиленового стекловолокна может иметь отличия вследствие использования переработанного материала

ACCESSORIES

CUSCINO DOGA RELAX

fabric

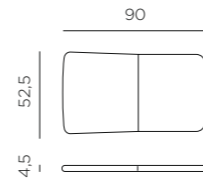

0,7 kg
n. pz. 4



lino
36256.00.152

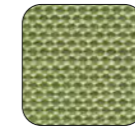

avocado
Sunbrella®
36256.00.139



fumo
Sunbrella®
36256.00.193

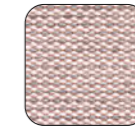

rosa
Sunbrella®
36256.00.222

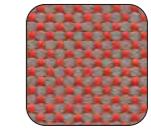

mattone
36256.00.221

CUSCINO DOGA ARMCHAIR

fabric



0,3 kg
n. pz. 4



lino
36254.00.152

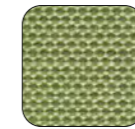

avocado
Sunbrella®
36254.00.139



fumo
Sunbrella®
36254.00.193

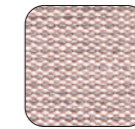

rosa
Sunbrella®
36254.00.222

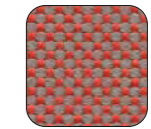

mattone
36254.00.221

CUSCINO DOGA BISTROT

fabric



0,3 kg
n. pz. 4



lino
36255.00.152

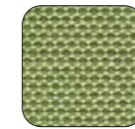

avocado
Sunbrella®
36255.00.139



fumo
Sunbrella®
36255.00.193

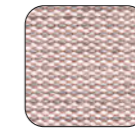

rosa
Sunbrella®
36255.00.222

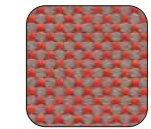

mattone
36255.00.221

CUSCINO NET BENCH

fabric

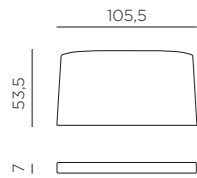

1,5 kg
n. pz. 4

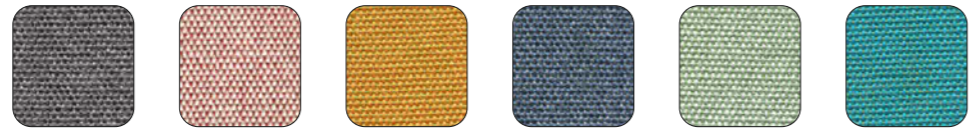

grey stone # 36338.00.064 rosa quarzo # 36338.00.066 senape # 36338.00.069 denim # 36338.00.070 the verde # 36338.00.071 sardinia # 36338.00.072

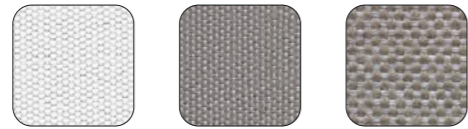

bianco 36338.00.155 grigio # 36338.00.163 grigio Sunbrella® * 36338.00.136

CUSCINO NET RELAX

fabric

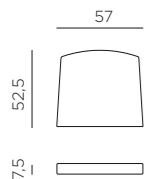

0,8 kg
n. pz. 4

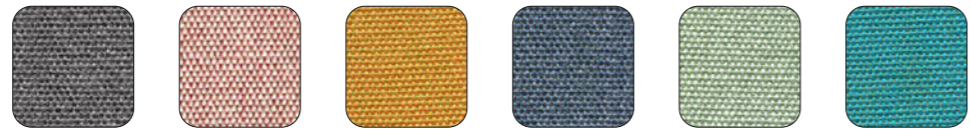

grey stone # 36327.00.064 rosa quarzo # 36327.00.066 senape # 36327.00.069 denim # 36327.00.070 the verde # 36327.00.071 sardinia # 36327.00.072



bianco 36327.00.155 grigio # 36327.00.163 grigio Sunbrella® * 36327.00.136

CUSCINO NET

fabric

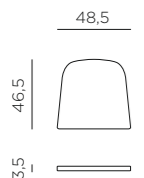

0,3 kg
n. pz. 4

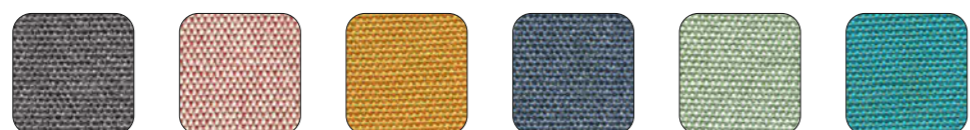

grey stone # 36326.00.064 rosa quarzo # 36326.00.066 senape # 36326.00.069 denim # 36326.00.070 the verde # 36326.00.071 sardinia # 36326.00.072



bianco 36326.00.155 grigio # 36326.00.163 grigio Sunbrella® * 36326.00.136

CUSCINO SHELL (NET RELAX)

fabric

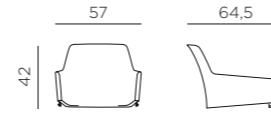

2,2 kg
n. pz. 2

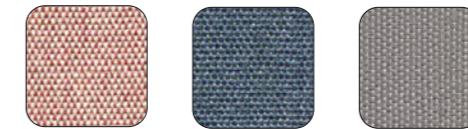

rosa quarzo # 36327.01.066 denim # 36327.01.070 grigio # 36327.01.163

Utilizzabile solo con cuscino Net Relax - Can only be used with Net Relax cushion - À utiliser uniquement avec le coussin Net Relax - Kann nur mit Net Relax Kissen verwendet werden - Se puede utilizar sólo con el cojín Net Relax - Só pode ser usada em conjunto com almofada de assento Net Relax - Sadece Net Relax minderiyile kullanilmalı - Можно использовать только с подушкой Net Relax.

CUSCINO BIT

fabric

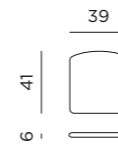

0,3 kg
n. pz. 4

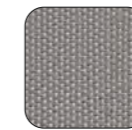

grigio # 36328.00.163

CUSCINO POGGIATESTA NET LOUNGE

fabric

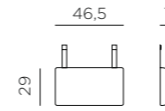

0,3 kg
n. pz. 4

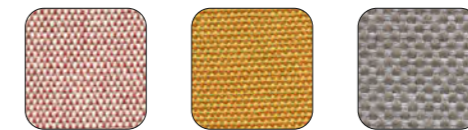

rosa quarzo # 36329.04.066 senape # 36329.04.069 grigio Sunbrella® 36329.04.136

TELO MARE NET LOUNGE

fabric

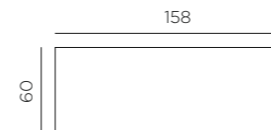

0,4 kg
n. pz. 12

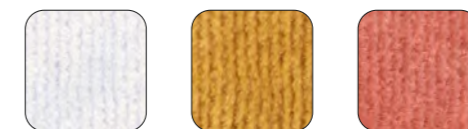

bianco 149329.60.050 senape 149329.65.650 corallo 149329.67.550

Variazioni di colore sono da ritenersi standard e naturali nei tessuti acrilici tinto filo. Posizionare in zone d'ombra - Colour variations are to be considered standard and natural in yarn-dyed acrylic fabrics. Position in shaded areas - Les variations de couleur des tissus acryliques au fil teint sont standard et naturelles. Placer dans des zones ombragées - Farbveränderungen sind als Standard und in im Garn gefärbten Acrylgeweben als natürlich zu betrachten. In schattigen Bereichen aufstellen - Las variaciones de color son normales y naturales en las telas acrílicas teñidas en hilo. Colocar en zonas de sombra - As variações de cor são consideradas standard e naturais nos tecidos acrílico tingidos com fio. Posicionar em zonas de sombra - Boyalı akrilik iplik kumaşlarda renk değişiklikleri standart ve doğal kabul edilir. Gölgeli alanlara yerleştiriniz - Изменения цвета следует считать нормой, они являются естественными в случае акриловых тканей с окрашенными волокнами. Размещать в тени

* Trattamento laminato su richiesta con quantità minima - Laminated finish available on request with a minimum quantity - Traitement laminé sur demande avec une quantité minimum - Laminierte Ausrüstung auf Anfrage mit einer Mindestmenge - Tratamiento laminado bajo pedido con una cantidad mínima - Tratamento laminado sob encomenda com quantidade mínima - Talep üzerine minimum miktarda lamine işlem - Ламинированная обработка по запросу с минимальным количеством

CUSCINO FOLIO COMFORT

fabric

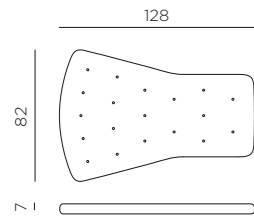

1,4 kg
n. pz. 1

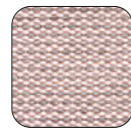

rosa
Sunbrella®
36300.01.222



artic
Sunbrella®
36300.01.223

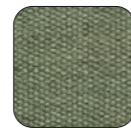

felce
Sunbrella®
36300.01.224

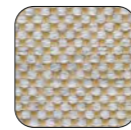

lino
36300.01.152



grigio #
36300.01.163

CUSCINO POGGIATESTA FOLIO

fabric

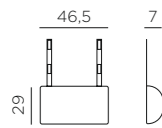

0,3 kg
n. pz. 4

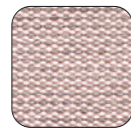

rosa
Sunbrella®
36300.04.222



artic
Sunbrella®
36300.04.223

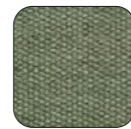

felce
Sunbrella®
36300.04.224

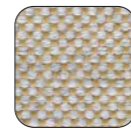

lino
36300.04.152



grigio #
36300.04.163

CUSCINO TRILL ARMCHAIR **new**

fabric

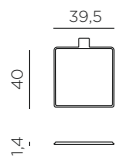

0,2 kg
n. pz. 4



grafite
36250.02.130

CUSCINO TRILL BISTROT

fabric

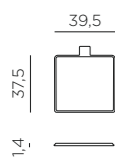

0,2 kg
n. pz. 4



grafite
36253.00.130

CUSCINO PLANO **new**

fabric

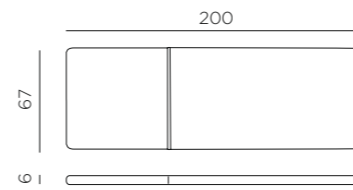

3,3 kg
n. pz. 1



lino
36462.00.152

CUSCINO PASSEPARTOUT

fabric

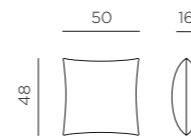

0,7 kg
n. pz. 4

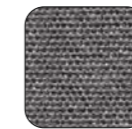

grey stone #
36000.01.064



rosa quarzo #
36000.01.066



senape #
36000.01.069

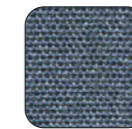

denim #
36000.01.070

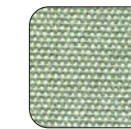

the verde #
36000.01.071

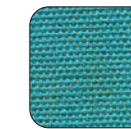

sardinia #
36000.01.072



tropical
36000.01.081



bianco
36000.01.155

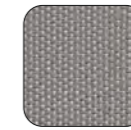

grigio #
36000.01.163



grigio
Sunbrella®
36000.01.136

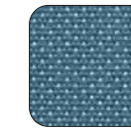

adriatic
Sunbrella®
36000.01.142

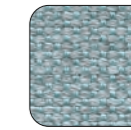

ghiaccio
Sunbrella®
36000.01.138

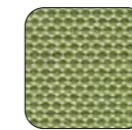

avocado
Sunbrella®
36000.01.139



giungla
Sunbrella®
36000.01.140

CUSCINO RETTANGOLARE

fabric

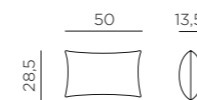

0,6 kg
n. pz. 4



rosa
quarzo #
36000.02.066



grigio #
36000.02.163



adriatic
Sunbrella®
36000.02.142

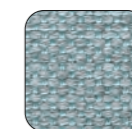

ghiaccio
Sunbrella®
36000.02.138



avocado
Sunbrella®
36000.02.139



giungla
Sunbrella®
36000.02.140

Variazioni di colore sono da ritenersi standard e naturali nei tessuti acrilici tinto filo. Posizionare in zone d'ombra - Colour variations are to be considered standard and natural in yarn-dyed acrylic fabrics. Position in shaded areas - Les variations de couleur des tissus acryliques au fil teint sont standard et naturelles. Placer dans des zones ombragées - Farbveränderungen sind als Standard und in im Garn gefärbten Acrylgeweben als natürlich zu betrachten. In schattigen Bereichen aufstellen - Las variaciones de color son normales y naturales en las telas acrílicas teñidas en hilo. Colocar en zonas de sombra - As variações de cor são consideradas standard e naturais nos tecidos acrílico tingidos com fio. Posicionar em zonas de sombra - Boyalı akrilik iplik kumaşlarda renk değişiklikleri standart ve doğal kabul edilir. Gölgeli alanlara yerleştiriniz - Изменения цвета следует считать нормой, они являются естественными в случае акриловых тканей с окрашенными волокнами. Размещать в тени

COVER MAXIMO S

(1 MAXIMO ELEMENT)

new

fabric

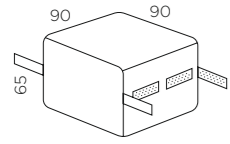

0,8 kg
n. pz. 25



smoke
37180.01.204

COVER MAXIMO M

(2 MAXIMO ELEMENTS)

new

fabric

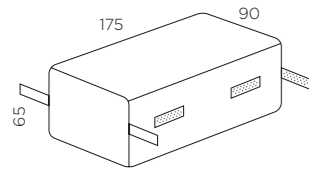

1,2 kg
n. pz. 20



smoke
37180.02.204

COVER MAXIMO L

(3 MAXIMO ELEMENTS)

new

fabric

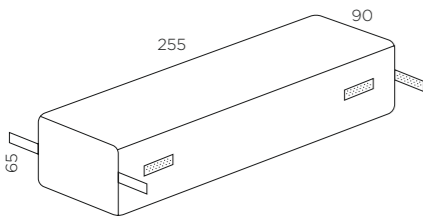

1,6 kg
n. pz. 15



smoke
37180.03.204

COVER S

(4/6 CHAIRS / 1 KOMODO ELEMENT)

fabric

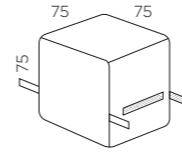

0,7 kg
n. pz. 25



smoke
37000.01.204

COVER M

(2/4 SUNLOUNGERS / PLANO MAX.3)

fabric

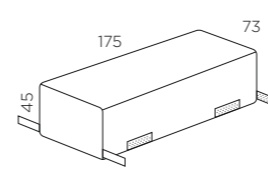

0,8 kg
n. pz. 20



smoke
37000.02.204

COVER L

(2 KOMODO ELEMENTS / TABLE 140)

fabric

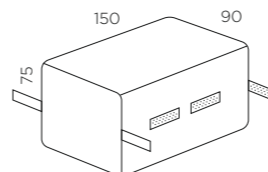

1,1 kg
n. pz. 20



smoke
37000.03.204

COVER XL

(3 KOMODO ELEMENTS / TABLE 210)

fabric

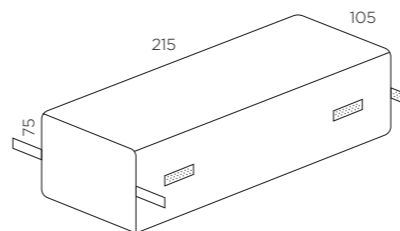

1,6 kg
n. pz. 15



smoke
37000.04.204

MATERIALS

polypropylene

Polipropilene trattato anti-UV e colorato in massa. Riciclabile al 100% - Polypropylene with UV additives and is uniformly colored. 100% Recyclable resin - Polypropylène traité anti-UV et coloré dans la masse. Résine recyclable 100% - UV-beständigem Polypropylen, voll durchgefärbt. 100% Recyclebarer Kunststoff - Polipropileno tratado anti-UV y teñido en masa. Resina reciclable 100% - Polipropileno com tratamento anti-UV colorido na totalidade. Resina reciclável 100% - Işığa dayanıklı ve boyalı olarak granül çekilmiş %100 geri dönüşümlü polipropilen kompozit hammadde - Полипропилен с обработкой анти-УФ, окрашенное в массе. На 100% пригодно для вторичной переработки.

fiberglass polypropylene

Polipropilene fiberglass trattato anti-UV e colorato in massa. Resina riciclabile al 100% - Uniformly colored fiberglass polypropylene resins with UV additives. 100% Recyclable resin - Polypropylène fiberglass traité anti-UV et coloré dans la masse. Résine recyclable 100% - Uv-beständigem fiberglass Polypropylen, voll durchgefärbt. 100% Recyclebarer Kunststoff - Polipropileno fiberglass tratado anti-UV y teñido en masa. Resina reciclable 100% - Polipropileno fiberglass com tratamento anti-UV colorido na totalidade. Resina reciclável 100% - Işığa dayanıklı ve boyalı olarak granül çekilmiş %100 geri dönüşümlü cam elyaf katkılı polipropilen kompozit hammadde - Полипропилен фиброволокно с обработкой анти-УФ, окрашенное в массе. На 100% пригодно для вторичной переработки.



BIANCO .00



GRIGIO .03



ANTRACITE .02



CORDA .24

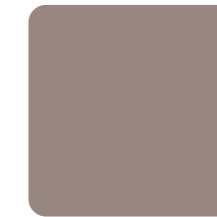

TORTORA .10

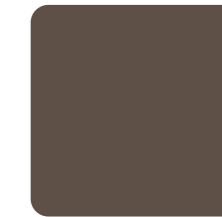

TABACCO .53



CAPPUCCINO .14



SENAPE .56



ROSSO .07



CORALLO .75



MARSALA .21

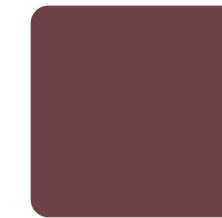

BORGOGNA 38



CELESTE .39



OTTANIO .49



MAYA .42



SALICE .04

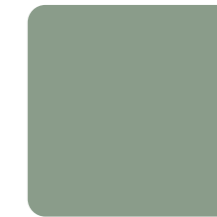

MENTA .15

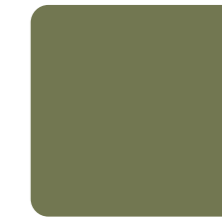

AGAVE .16



PERA .18

regenerated fiberglass polypropylene

Polipropilene fiberglass rigenerato trattato anti-UV e colorato in massa. Resina riciclabile al 100% - Regenerated uniformly colored fiberglass polypropylene resins with UV additives. 100% Recyclable resin - Polypropylène fiberglass régénérée traité anti-UV et coloré dans la masse. Résine recyclable 100% - Regeneriertem UV-beständigem fiberglass-Polypropylen, voll durchgefärbt. 100% Recyclebarer Kunststoff - Polipropileno fiberglass regenerado tratado

anti-UV y teñido en masa. Resina reciclable 100% - Polipropileno fiberglass regenerado com tratamento anti-UV colorido na totalidade. Resina reciclável 100% - UV katlı maddeleriyle fiberglass polipropilen reçine ile renklendirilip düzgün bir şekilde tekrar oluşturulmuştur - Переработанный, крашенный, полипропилен fiberglass обработанный против проникновения ультрафиолетовых лучей. На 100% пригоден для вторичной переработки.



TERRA .44

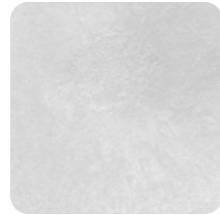

GESSO .29

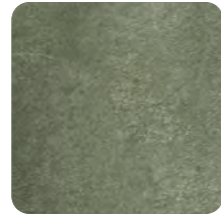

CACTUS .27

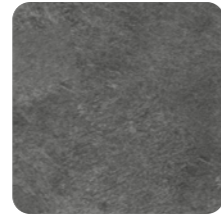

BASALTO .25

Il polipropilene fiberglass rigenerato può presentare delle variazioni di colore dovute all'utilizzo di materiale riciclato - Regenerated fiberglass polypropylene may vary in color due to the use of recycled material - Polypropylène fiberglass régénéré peut présenter variations de couleur en raison de l'utilisation de matériaux recyclés - Regeneriertem fiberglass-Polypropylen kann aufgrund der Verwendung von recyceltem Material Farbunterschiede aufweisen - El polipropileno fiberglass regenerado puede presentar

variaciones de color debido al uso de material reciclado - O polipropileno fiberglass regenerado pode apresentar variações de cor devido ao uso de material reciclado - Rejenere edilmiş polipropilen fiberglass, geri dönüşüm malzemesi kullanımı nedeniyle renk değişikliklerine maruz kalabilir - цвет регенерированного полипропиленового стекловолокна может иметь отличия вследствие использования переработанного материала

Sunbrella® acrylic fabric



100% fibra acrilica Sunbrella® tinto in massa. Trattamento idrorepellente, antimacchia, antimuffa. Solidità alla luce 8/8. Lavabile a 30° - 100% Sunbrella® acrylic fiber mass dyed. Water repellent treatment, dirt repellent and anti-mould treatment. 8/8 light fastness. Washable at 30° - 100% fibre acrylique Sunbrella® teintée en masse. Traitement hydrofuge, anti-taches et anti-moisissure. Résistance à la lumière 8/8. Lavable à 30° - 100% fasergefärbtes Sunbrella® Polyacryl. Wasserabweisend Ausrüstung, gegen Flecken und Schimmel ausgerüstet. Lichtechtheit 8/8. Waschbar bei 30° - 100% fibra acrílica

Sunbrella® tintada em massa. Tratamiento por la repelencia al agua, protección antimanchas, antimoho. Solidez a la luz 8/8. Lavable a 30° - 100% fibra acrílica Sunbrella® tingida em massa. Tratamento hidrorrepelente, antimancha e antimoho. Resistência à luz 8/8. Lavável a 30° - %100 akrilik elyaf Sunbrella® çözelti halinde boyanmış. Su itici, leke itici, küf önleyici ile muamele edilmiş. Işık haslığı 8/8. 30°de yıkanabilir - 100% акриловое волокно Sunbrella®, окрашенное в массе. Водоотталкивающая, пятноустойчивая и противоплесневая обработка. Светостойкость 8/8. Стирать при 30°.



grigio
Sunbrella® .136
275 gr/m²



canvas
Sunbrella® .141
275 gr/m²

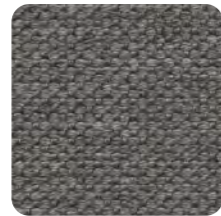

fumo
Sunbrella® .193
275 gr/m²

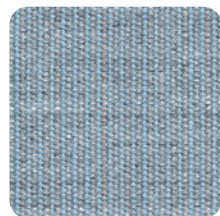

artic
Sunbrella® .223
260 gr/m²

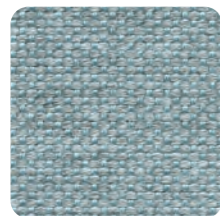

ghiaccio
Sunbrella® .138
275 gr/m²



adriatic
Sunbrella® .142
260 gr/m²

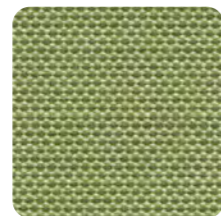

avocado
Sunbrella® .139
260 gr/m²



felce
Sunbrella® .224
260 gr/m²



rosa
Sunbrella® .222
275 gr/m²

Sunbrella® EXTRA



Tessuti disponibili su ordinazione per minimi quantitativi d'ordine solo per il prodotto KOMODO - Fabrics available to order for minimum order quantities for the KOMODO product only - Tissus disponibles sur commande de quantités minimales pour le produit KOMODO uniquement - Gewebe auf Bestellung für Mindestbestellmengen nur für das Produkt KOMODO erhältlich

- Telas disponibles bajo pedido para cantidades mínimas solo para el producto KOMODO - Tecidos disponíveis por encomenda para quantidades mínimas de encomenda apenas para o produto KOMODO - Sadece KOMODO ürünü için minimum sipariş miktarına göre sipariş verilebilecek kumaşlar - ткани на заказ для минимального объема заказа только для изделия KOMODO.



marble
Sunbrella® .186
260 gr/m²

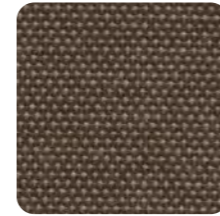

mink brown
Sunbrella® .183
260 gr/m²

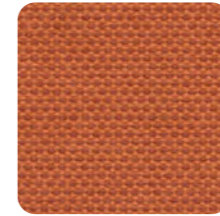

pumpkin
Sunbrella® .184
260 gr/m²

laminated treatment

(Su richiesta - On request - Sur demande - Auf Anfrage - Bajo pedido - Sob encomenda - İstek üzerine - По запросу)



Il tessuto è accoppiato internamente con un film in poliuretano che lo rende impermeabile. La parte accoppiata in poliuretano non deve essere esposta al sole. Applicabile su richiesta con quantità minima su tessuti acrilici Sunbrella® - The fabric is bonded with a polyurethane film that makes it waterproof. The polyurethane laminated surface should not be exposed to direct sunlight. Applicabile on Sunbrella® acrylic fabrics on request with a minimum quantity - Le tissu est doublé en interne avec un film de polyuréthane qui le rend imperméable. La partie en polyuréthane ne doit pas être exposée au soleil. Applicable sur demande avec une quantité minimale sur les tissus acryliques Sunbrella® - Das Gewebe ist innen mit einer Polyurethanfolie verbunden, die es wasserdicht macht. Das mit Polyurethan verbundene Teil darf nicht der Sonne ausgesetzt werden. Auf Anfrage mit Mindestmenge auf Sunbrella® Polyacryl Gewebe anwendbar - El tejido

está acoplado internamente con una película de poliuretano que lo hace impermeable. La parte acoplada de poliuretano no debe exponerse al sol. Aplicable bajo pedido con una cantidad mínima en tejidos acrílicos Sunbrella® - O tecido é dublado com filme interno de poliuretano que o torna impermeável. O lado que possui o filme de poliuretano não pode ser exposta ao sol. Aplicável sob encomenda, com quantidade mínima, em tecidos acrílicos Sunbrella® - Kumaş, su geçirmez hale getiren bir poliüretan film ile dahili olarak birleştirilmiştir. Birleştirilmiş poliüretan bölümler güneşe maruz bırakılmamalıdır. Sunbrella® akrilik kumaşlar üzerine minimum miktarda istek üzerine uygulanabilir - Ткань внутренне соединена с полиуретановой пленкой, которая делает ее водонепроницаемой. та часть ,где имеется добавка полиуритана не выставлять на солнце. Применяется по запросу с минимальным количеством на акриловых тканях Sunbrella®.

mass dyed acrylic fabric



100% fibra acrilica tinto in massa. Trattamento idrorepellente, antimacchia, antimuffa. Solidità alla luce 7/8. Lavabile a 30° - 100% acrylic fiber mass dyed. Water repellent treatment, dirt repellent and anti-mould treatment. 7/8 light fastness. Washable at 30° - 100% fibre acrylique teintée en masse. Traitement hydrofuge, anti-taches et anti-moisissure. Résistance à la lumière 7/8. Lavable à 30° - 100% fasergefärbtes Polyacryl. Wasserabweisend Ausrüstung, gegen Flecken und Schimmel ausgerüstet. Lichtechtheit 7/8. Waschbar bei 30° -

100% fibra acrílica tintada em massa. Tratamiento hidropelente, protección antimanchas, antimoho. Solidez a la luz 7/8. Lavable a 30° - 100% fibra acrílica tingida em massa. Tratamento hidrorrepelente, antimancha e antimoho. Resistência à luz 7/8. Lavável a 30° - %100 akrilik elyaf çözelti halinde boyanmış. Su itici, leke itici, küf önleyici ile muamele edilmiş. Işık haslığı 7/8. 30°de yıkanabilir - 100% акриловое волокно окрашенное в массе. Водоотталкивающая, пятноустойчивая и противоплесневая обработка. Светостойкость 7/8. Стирать при 30°.



lino .152
280 gr/m²

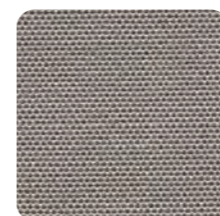

grigio Komodo .172
240 gr/m²

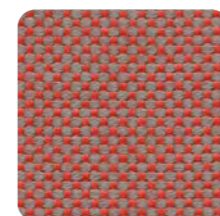

mattone .221
280 gr/m²

recycled Sunbrella® acrylic fabric



50% fibra acrilica Sunbrella® riciclata tinto in massa, 47% fibra acrilica Sunbrella® tinto in massa, 3% poliester. Solidità alla luce 8/8, lavabile a 30°, trattamento Non PFAS idrorepellente, antimacchia. - 50% recycled Sunbrella® acrylic fiber mass dyed, 47% Sunbrella® acrylic fiber mass dyed, 3% polyester. 8/8 light fastness, washable at 30°, non-PFAS water-repellent, stain-proof treatment. - 50% fibre acrylique Sunbrella® recyclée teintée en masse, 47% fibre acrylique Sunbrella® teintée en masse, 3% de polyester. Résistance à la lumière 8/8, lavable à 30°, traitement hydrofuge sans PFAS et anti-taches. - 50% fasergefärbtes, recyceltes Sunbrella® Polyacryl, 47% fasergefärbtes Sunbrella® Polyacryl, 3% Polyester. Lichtechtheit 8/8, waschbar bei 30°, Wasser- und fleckabweisende Beschichtung ohne PFAS. - 50% fibra acrilica Sunbrella® reciclada tintada en masa, 47% fibra acrilica Sunbrella® tintada

en masa, 3% poliéster. Solidez a la luz 8/8, lavable a 30°, tratamiento sin PFAS, hidrorrepelente, antimancha. - 50% fibra acrílica Sunbrella® reciclada tingida em massa, 47% fibra acrílica Sunbrella® tingida em massa, 3% de poliéster. Resistência à luz 8/8, lavável a 30°, tratamento sem perfluorados (PFAS) hidrorrepelente, anti-mancha. - %50 geri dönüştürülmüş akrilik elyaf Sunbrella® çözelti halindeyken boyanmış, %47 akrilik elyaf Sunbrella® çözelti halindeyken boyanmış, % 3 polyester. Işığa dayanıklılık 8/8, 30°'de yıkanabilir, PFAS içermeyen su geçirmez, leke tutmaz işlem. - 50% переработанное акриловое волокно Sunbrella®, окрашенное в массу, 47% акриловое волокно Sunbrella®, окрашенное в массу, 3% полиэстер. Светостойкость 8/8, стирка при 30°, водоотталкивающая обработка без ПФАС, грязеотталкивающая



perla
Sunbrella® .213
365 gr/m²



lava
Sunbrella® .215
365 gr/m²

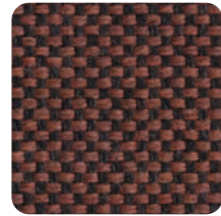

cannella
Sunbrella® .219
365 gr/m²

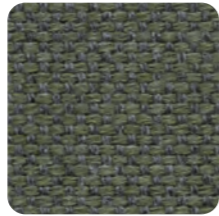

timo
Sunbrella® .217
365 gr/m²



giungla
Sunbrella® .140
340 gr/m²

33% fibra acrilica Sunbrella® riciclata tinto in massa, 65% fibra acrilica Sunbrella® tinto in massa, 2% poliester. Solidità alla luce 8/8, lavabile a 30°, trattamento Non PFAS idrorepellente, antimacchia. - 33% recycled Sunbrella® acrylic fiber mass dyed, 65% Sunbrella® acrylic fiber mass dyed, 2% polyester. 8/8 light fastness, washable at 30°, non-PFAS water-repellent, stain-proof treatment. - 33% fibre acrylique Sunbrella® recyclée teintée en masse, 65% fibre acrylique Sunbrella® teintée en masse, 2% de polyester. - Résistance à la lumière 8/8, lavable à 30°, traitement hydrofuge sans PFAS et anti-tache. - 33% fasergefärbtes, recyceltes Sunbrella® Polyacryl, 65% fasergefärbtes Sunbrella® Polyacryl, 2% Polyester. Lichtechtheit 8/8, waschbar bei 30°, Wasser- und fleckabweisende Beschichtung ohne PFAS. - 33% fibra acrilica Sunbrella® reciclada tintada en masa, 65% fibra acrilica Sunbrella® tintada

en masa, 2% poliéster. Solidez a la luz 8/8, lavable a 30°, tratamiento sin PFAS, hidrorrepelente, antimancha. - 33% fibra acrílica Sunbrella® reciclada tingida em massa, 65% fibra acrílica Sunbrella® tingida em massa, 2% de poliéster. Resistência à luz 8/8, lavável a 30°, tratamento sem perfluorados (PFAS) hidrorrepelente, anti-mancha. - %33 geri dönüştürülmüş akrilik elyaf Sunbrella® çözelti halindeyken boyanmış, %65 akrilik elyaf Sunbrella® çözelti halindeyken boyanmış, % 2 polyester. Işığa dayanıklılık 8/8, 30°'de yıkanabilir, PFAS içermeyen su geçirmez, leke tutmaz işlem. - 33% переработанное акриловое волокно Sunbrella®, окрашенное в массу, 65% акриловое волокно Sunbrella®, окрашенное в массу, 2% полиэстер. Светостойкость 8/8, стирка при 30°, водоотталкивающая обработка без ПФАС, грязеотталкивающая



perla arredo
Sunbrella® .214
365 gr/m²



lava arredo
Sunbrella® .216
365 gr/m²



cannella arredo
Sunbrella® .220
365 gr/m²



timo arredo
Sunbrella® .218
365 gr/m²

Il tessuto rigenerato Sunbrella può presentare delle variazioni di colore dovute all'utilizzo di materiale riciclato - The Sunbrella regenerated fabric may vary in color due to the use of recycled material - Le tissu régénéré Sunbrella peut présenter variations de couleur en raison de l'utilisation de matériaux recyclés - Das regenerierte Gewebe Sunbrella kann aufgrund der Verwendung von recyceltem Material Farbunterschiede aufweisen - El tejido regenerado Sunbrella puede presentar variaciones de color debido al uso de material reciclado - O tecido regenerado Sunbrella pode apresentar variações de cor devido ao uso de material reciclado - Sunbrella rejenere kumaş, geri dönüştürülmüş malzeme kullanımı nedeniyle renk farklılıkları gösterebilir - цвет регенерированной ткани Sunbrella может иметь отличия вследствие использования переработанного материала

recycled Sunbrella® EXTRA



Tessuti disponibili su ordinazione per minimi quantitativi d'ordine solo per il prodotto MAXIMO - Fabrics available to order for minimum order quantities for the MAXIMO product only - Tissus disponibles sur commande de quantités minimales pour le produit MAXIMO uniquement - Gewebe auf Bestellung für Mindestbestellmengen nur für das Produkt MAXIMO erhältlich -

Telas disponibles bajo pedido para cantidades mínimas solo para el producto MAXIMO - Tecidos disponíveis por encomenda para quantidades mínimas de encomenda apenas para o produto MAXIMO - Sadece MAXIMO ürünü için minimum sipariş miktarına göre sipariş verilebilecek kumaşlar - ткани на заказ для минимального объема заказа только для изделия MAXIMO.

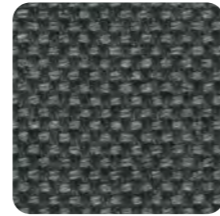

fogo
Sunbrella® .237
365 gr/m²



coal
Sunbrella® .231
365 gr/m²



ebene
Sunbrella® .232
365 gr/m²



nori
Sunbrella® .234
365 gr/m²



loch
Sunbrella® .233
365 gr/m²



tile
Sunbrella® .235
365 gr/m²



sencha
Sunbrella® .236
365 gr/m²



spirea arredo
Sunbrella® .230
470 gr/m²



forest arredo
Sunbrella® .228
470 gr/m²



grizzly arredo
Sunbrella® .229
470 gr/m²

thermoformed Cuscino Trill



100% fibra acrilica tinto in massa. Trattamento idrorepellente, antimacchia, antimuffa. Solidità alla luce 7-8/8. Senza cuciture. Lavabile a 30°. Imbottitura: poliuretano espanso rivestito da una membrana TPU waterproof. Densità 40 kg/m³ - 100% acrylic fiber mass dyed. Water repellent treatment, dirt repellent and anti-mould treatment. 7-8/8 light fastness. Seamless. Washable at 30°. Padding: polyurethane foam with a TPU waterproof membrane coating. Density 40 kg/m³ - 100 % fibre acrylique teintée en masse. Traitement hydrofuge, anti-taches e anti-moisissure. Résistance à la lumière 7-8/8. Sans couture. Lavable à 30°. Rembourrage: mousse polyuréthane revêtu d'une membrane TPU imperméable. Densité 40 kg/m³ - 100 % fasergefärbtes Polyacryl. Wasserabweisend Ausrüstung, gegen Flecken und Schimmel ausgerüstet. Lichtechtheit 7-8/8. Ohne Nähte. Waschbar bei 30°. Polsterung: Polyurethanschaum mit einer wasserdichten TPU-Membran abgedeckt. Dichte

40 kg/m³ - 100% fibra acrílica tintada en masa. Tratamiento hidropelente, protección antimanchas, antimoho. Solidez a la luz 7-8/8. Sin costuras. Lavable a 30°. Relleno: espuma de poliuretano recubierto con una membrana de TPU impermeable. Densidad 40 kg/m³ - 100% fibra acrílica tingida em massa. Tratamento hidrorrepelente, antimancha e antimoho. Resistência à luz 7-8/8. Sem costuras. Lavável a 30°. Enchimento: espuma de poliuretano com cobertura de membrana TPU impermeável. Densidade 40 kg/m³ - %100 akrilik elyaf çözelti halindeyken boyanmış. Su itici, leke itici, küf önleyici ile muamele edilmiş. Işık haslığı 7-8/8. Dikişsiz. 30°'de yıkanabilir. Dolgu malzemesi: TPU waterproof film ile kaplanmış poliüretan köpük. Yoğunluk 40 kg/m³ - 100% акриловое волокно окрашенное в массу. Водоотталкивающая, пятноустойчивая и противогрибковая обработка. Светостойкость 7-8/8. Без швов. Стирать при 30°. Набивка: пенополиуретан с покрытием из водостойкой мембраны ТПУ. Плотность 40 кг/м³.

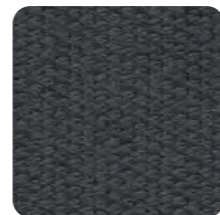

grafite .130
500 gr/m²

acrylic fabric

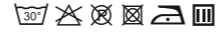

Fibra acrilica 100% tinto filo. Trattamento antimacchia, antimuffa. Solidità alla luce 5/8. Lavabile a 30° - 100% yarn dyed acrylic. Dirt repellent and anti-mould treatment. 5/8 light fastness. Washable at 30° - 100% fibre acrylique teintée en fils. Traitement anti-taches et anti-moisissure. Résistance à la lumière 5/8. Lavable à 30° - 100% garnegefärbtes Polyacryl Gewebe. Gegen Flecken und Schimmel Ausrüstung. Lichtechtheit 5/8. Waschbar bei 30° - 100% hilo teñido

acrílico. Protección antimanchas, antimoho. Solidez a la luz 5/8. Lavable a 30° - 100% fibra acrílica tingida com fio. Tratamento antimancha e antimoho. Resistência à luz 5/8. Lavável a 30° - %100 akrilik elyaf boyalı iplik. Leke itici, küf önleyici ile muamele edilmiş. Işık haslığı 5/8. 30°de yıkanabilir - Акриловое волокно 100% окрашенное в пряже. Пятноустойчивая и противоплесневая обработка. Светостойкость 5/8. Стирать при 30°.

Variazioni di colore sono da ritenersi standard e naturali nei tessuti acrilici tinto filo. Posizionare in zone d'ombra - Colour variations are to be considered standard and natural in yarn-dyed acrylic fabrics. Position in shaded areas - Les variations de couleur des tissus acryliques au fil teint sont standard et naturelles. Placer dans des zones ombragées - Farbveränderungen sind als Standard und in im Garn gefärbten Acrylgeweben als natürlich zu betrachten. In schattigen Bereichen aufstellen - Las variaciones de color son normales y naturales en las telas acrílicas teñidas en hilo. Colocar en zonas de sombra - As variações de cor são consideradas standard e naturais nos tecidos acrílico tingidos com fio. Posicionar em zonas de sombra - Boyalı akrilik iplik kumaşlarda renk değişiklikleri standart ve doğal kabul edilir. Gölgeli alanlara yerleştiriniz - Изменения цвета следует считать нормой, они являются естественными в случае акриловых тканей с окрашенными волокнами. Размещать в тени.



grigio .163
240 gr/m²

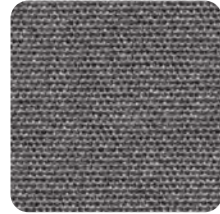

grey stone .064
240 gr/m²

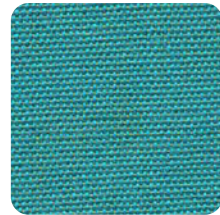

sardinia .072
240 gr/m²

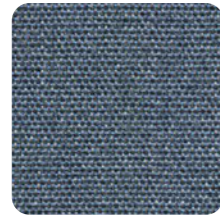

denim .070
240 gr/m²

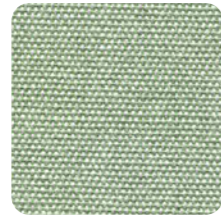

the verde .071
240 gr/m²

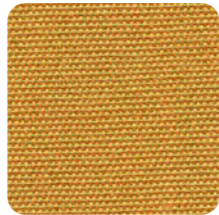

senape .069
240 gr/m²

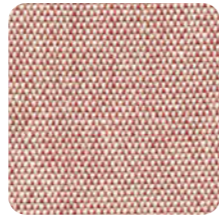

rosa quarzo .066
240 gr/m²

acrylic fabric with digital print



Fibra acrilica 100% stampa digitale. Solidità alla luce 6. Lavabile a 30° - 100% acrylic fiber with digital print. 6 light fastness. Washable at 30° - 100% fibre acrylique impression numérique. Résistance à la lumière 6. Lavable à 30° - 100% Polyacrylfaser mit Digitaldruck. Lichtechtheit 6. Waschbar bei 30° - 100%

fibra acrílica impresión digital. Solidez a la luz 6. Lavable a 30° - 100% fibra acrílica estampa digital. Resistência à luz 6. Lavável a 30° - %100 dijital baskı akrilik elyaf. Işık haslığı 6. 30°de yıkanabilir - 100% акриловое волокно с цифровым рисунком, окрашенное в процессе производства. Светостойкость 6. Стирка при 30°.



tropical .081
190 gr/m²

TECH



50% vinile e 50% poliestere. Trattamento idrorepellente, antimacchia, antimuffa, ignifugo e antibatterico. Solidità alla luce 6. Lavare a mano in acqua fredda. Alla base dei cuscini seduta comodo TECH panama viene applicata una rete a maglia larga in poliestere per permettere la traspirazione - 50% vinyl and 50% polyester. The treatment makes the coating: water repellent, and resistant to staining, resistant to mold, fire retardant, and antibacterial. 6 light fastness. Hand wash in cold water. At the bottom of the komodo seat cushions, made with TECH panama, the fabric is a polyester wide mesh to allow breathability - 50% vinyle et 50% polyester. Traitement hydrofuge, anti-taches, anti-moisissures, ignifugé et antibactérien. Résistance à la lumière 6. Laver à la main à l'eau froide. À la base des coussins d'assise comodo TECH panama, un filet de polyester à larges mailles est appliqué pour évacuer la transpiration - 50% Vinyl und 50% Polyester. Wasserabweisend, gegen Flecken und Schimmelbildung ausgerüstet, feuerfest und antibakteriell. Lichtechtheit 6. Handwäsche in kaltem Wasser. Auf der Unterseite der TECH panama Komodo-Sitzkissen ist ein atmungsaktives Polyesternetz mit großer Maschenweite angebracht,

um Luftaustausch zu ermöglichen - 50% vinilo y 50% poliéster. Tratamiento para repeler el agua, ignifugo y antibacteriano, protección antimanchas, antimoho. Solidez a la luz 6. Lavar a mano en agua fría. En la base de los cojines de asiento del komodo TECH panama, se aplica una red de poliéster de malla ancha para permitir la transpiración - 50% de vinil e 50% de poliéster. Tratamento hidrorepelente, antimancha e antimoho, resistente ao fogo e antibacteriano. Resistência à luz 6. Lavar à mão em água fria. Na base das almofadas do assento de comodo TECH panama, é aplicada uma tela de poliéster de malha larga para permitir a transpiração - % 50 vinil ve % 50 polyester. Su Geçirmez Uygulama, kir tutmaz ve küf önleyici uygulama, yangın geciktirici ve antibakteriyel uygulama. Işık haslığı 6. Gerektiğinde, el ile soğuk suda yıkanabilir. Hava alması için komodo'nun altında TECH panama minderle, geniş fileli polyester uygulanmıştır - 50% винил и 50% полиэстер. типы обработки: водоталкивающая, пятноталкивающая, плесеньоталкивающая, невоzгараемая и антибактериальная устойчивость к . Светостойкость 6. Ручная стирка в холодной воде. в основе подушек comodo материал Tech panama добавлена сетка с широкой вязкой из полиэстера, чтобы материал проветривался.



TECH panama .131
830 gr/m²

100% Olefin fabric



100% Olefin tinto in massa. Trattamento antimacchia, antimuffa. Solidità alla luce 7/8. Lavabile a 40° - 100% Olefin mass dyed. Dirt repellent and anti-mould treatment. 7/8 light fastness. Washable at 40° - 100% Olefin teintée en masse. Traitement anti-taches et anti-moisissure. Résistance à la lumière 7/8. Lavable à 40° - 100% fasergefärbtes Olefin. Gegen Flecken und Schimmel Ausrüstung. Lichtechtheit 7/8. Waschbar bei 40° - 100% Olefin tintada

en masa. Protección antimanchas, antimoho. Solidez a la luz 7/8. Lavable a 40° - 100% Olefin tingida em massa. Tratamento antimancha e antimoho. Resistência à luz 7/8. Lavável a 40° - %100 Olefin çözültü halindeyken boyanmış. Leke itici, küf önleyici ile muamele edilmiş. Işık haslığı 7/8. 40°de yıkanabilir - 100% Olefin, окрашенный в массе. Пятноустойчивая и противоплесневая обработка. Светостойкость 7/8. Стирать при 40°.

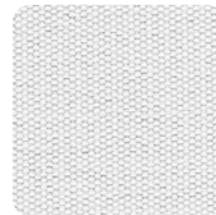

bianco .155
190 gr/m²

mass dyed acrylic fabric for Komodo Ombra



100% fibra acrilica tinto in massa. Trattamento idrorepellente, antimacchia, antimuffa. Solidità alla luce 7-8/8. Lavabile a 30°. Il tessuto Velo deve essere impiegato solo come telo-parasole. La maglia larga permette l'areazione e allo stesso tempo crea una zona d'ombra sottostante ma non trattiene l'acqua - 100% acrylic fiber mass dyed. Water repellent treatment, dirt repellent and anti-mould treatment. 7-8/8 light fastness. Washable at 30°. Velo fabric should only be used for sunshades. Its wide mesh allows ventilation while creating a shaded area below, but it does not retain water - 100% fibre acrylique teintée en masse. Traitement hydrofuge, anti-taches et anti-moisissure. Résistance à la lumière 7-8/8. Lavable à 30°. Le tissu Velo ne doit être utilisé que comme toile de parasol. Les mailles larges permettant de s'aérer tout en créant, en même temps, une zone d'ombre en dessous. Velo n'est pas imperméable - 100% fasergefärbtes Polyacryl. Wasserabweisend Ausrüstung, gegen Flecken und Schimmel ausgerüstet. Lichtechtheit 7-8/8. Waschbar bei 30°. Das Gewebe Velo darf nur als Sonnenschutztuch verwendet werden. Die großen Maschen gestatten die Belüftung und gleichzeitig bildet sich darunter ein Schattenbereich, doch es hält Wasser nicht



velo white .203

150 gr/m²

telo mare Net Lounge

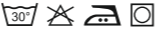

100% cotone. Trattamento IDH. Solidità alla luce 4/5. Lavabile a 30°, programma delicati - 100% cotton. IDH treatment. 4/5 light fastness. Washable at 30°C, delicates programme - 100 % coton. Traitement IDH. Résistance à la lumière 4/5. Lavable à 30°, programme délicat - 100 % Baumwolle. Ausrüstung: Indanthren. Lichtechtheit 4/5. Waschbar bei 30°, Schonprogramm - 100% algodón. Tratamiento IDH. Solidez a la luz 4/5. Lavable a



bianco .600

550 gr/m²



senape .656

550 gr/m²



corallo .675

550 gr/m²

zurück - 100% fibra acrilica tintada en masa. Tratamiento hidropelente, protección antimanchas, antimoho. Solidez a la luz 7-8/8. Lavable a 30°. La tela Velo debe utilizarse únicamente como parasol, la malla ancha permite la ventilación y crea por debajo una zona de sombra, pero no protege del agua - 100% fibra acrílica tingida em massa. Tratamento hidrorepelente, antimancha e antimoho. Resistência à luz 7-8/8. Lavável a 30°. O tecido Velo deve ser utilizado apenas como pano guarda-sol, a malha larga permite o arejamento e ao mesmo tempo cria uma zona de sombra subjacente, mas não retém a água - %100 akrilik elyaf çözelti halindeyken boyanmış. Su itici, leke itici, küf önleyici ile muamele edilmiş. Işık haslıđı 7-8/8. 30°de yıkanabilir. Velo dokuma sadece güneşlik olarak kullanılmalıdır, geniş gözenekler havalandırma sağlar ve aynı zamanda aşağıda bir gölge alanı oluşturur, fakat su tutma özelliđi yoktur - 100% акриловое волокно, окрашенное в массе. Водоотталкивающая, пятноустойчивая и противоплесневая обработка. Светостойкость 7-8/8. стирать при 30°. Ткань Velo предназначена исключительно для использования в качестве тента для защиты от солнца. Переплетение в виде крупной сетки обеспечивает вентиляцию и в то же время создает затенение под собой, но не задерживает влагу.

padding

CUSCINO FOLIO COMFORT

Poliuretano espanso (densità 18 kg/m³) rivestito da fibra di poliestere accoppiata al tessuto - Polyurethane foam (density 18 kg/m³) with a polyester fiber coating bonded to the fabric - Mousse polyuréthane (densité 18 kg/m³) revêtu de fibre de polyester couplé au tissu - Polyurethanschäum (Dichte 18 kg/m³) mit Polyesterfasern beschichtet, gekoppelt mit dem Gewebe - Espuma de poliuretano (densidad 18 kg/m³) cubierta con fibras de poliéster acoplada con el tejido - Espuma de poliuretano (densidade 18 kg/m³) com cobertura fibras de poliéster acoplada ao tecido - Kumaşa birleştirilmiş polyester elyafla kaplanmış genişletilmiş poliüretan (yoğunluk 18 kg/m³) - Расширенный полиуретан (плотность 18 кг/м³), покрытый полиэфирным волокном, соединенным с тканью.

CUSCINO NET BENCH - CUSCINO NET RELAX - CUSCINO NET

Poliuretano espanso. Densità 28 kg/m³ - Polyurethane foam. Density 28 kg/m³ - Mousse polyuréthane. Densité 28 kg/m³. Polyurethanschäum - Dichte 28 kg/m³ - Espuma de poliuretano. Densidad 28 kg/m - Espuma de poliuretano. Densidade 28 kg/m³ - Poliüretan köpük. Yoğunluk 28 kg/m³ - Пенополиуретан. Плотность 28 кг/м³.

CUSCINO SHELL NET RELAX

Poliuretano espanso su struttura rigida di polipropilene. Densità 70 kg/m³ - Polyurethane foam over solid polypropylene frame. Density 70 kg/m³ - Mousse polyuréthane sur structure rigide de polypropylène. Densité 70 kg/m³ - Polyurethanschäum auf steifer Polypropylengestell. Dichte 70 kg/m³ - Espuma de poliuretano sobre estructura rígida de polipropileno. Densidad 70 kg/m³ - Espuma de poliuretano sobre estrutura rígida de polipropileno. Densidade 70 kg/m³ - Sert polipropilen gövde üzerinde poliüretan köpük minder. Yoğunluk 70 kg/m³ - Пенополиуретан. на жесткой конструкции из полипропилена. Плотность 70 кг/м³.

CUSCINO BIT

Poliuretano espanso (densità 17,10 kg/m³) rivestito da fibra di poliestere (densità 200 gr/m²) - Polyurethane foam (density 17,10 kg/m³) with a polyester fiber coating (density 200 gr/m²) - Mousse polyuréthane (densité 17,10 kg/m³) revêtu de fibre de polyester (densité 200 gr/m²) - Polyurethanschäum (Dichte 17,10 kg/m³) mit Polyesterfasern beschichtet (Dichte 200 gr/m²) - Espuma de poliuretano (densidad 17,10 kg/m³) cubierta con fibras de poliéster (densidad 200 gr/m²) - Espuma de poliuretano (densidade 17,10 kg/m³) com cobertura fibras de poliéster (densidade 200 gr/m²) - Polyester elyaf (Yoğunluk 200 gr/m²) kaplı köpük poliüretan (Yoğunluk 17,10 kg/m³) - Пенополиуретан (Плотность 17,10 кг/м³) с покрытием из обшивка из полиэстера (Плотность 200 гр/м²).

CUSCINO DOGA RELAX - CUSCINO DOGA ARMCHAIR - CUSCINO DOGA BISTROT

Poliuretano espanso (densità 18 kg/m³) rivestito da fibra di poliestere (densità 100 gr/m²) - Polyurethane foam (density 18 kg/m³) with a polyester fiber coating (density 100 gr/m²) - Mousse polyuréthane (densité 18 kg/m³) revêtu de fibre de polyester (densité 100 gr/m²) - Polyurethanschäum (Dichte 18 kg/m³) mit Polyesterfasern beschichtet (Dichte 100 gr/m²) - Espuma de poliuretano (densidad 18 kg/m³) cubierta con fibras de poliéster (densidad 100 gr/m²) - Espuma de poliuretano (densidade 18 kg/m³) com cobertura fibras de poliéster (densidade 100 gr/m²) - Polyester elyaf (Yoğunluk 100 gr/m²) kaplı köpük poliüretan (Yoğunluk 18 kg/m³) - Пенополиуретан (Плотность 18 кг/м³) с покрытием из обшивка из полиэстера (Плотность 100 гр/м²).

CUSCINO SEDUTA MAXIMO

Poliuretano espanso (densità 25 kg/m³) rivestito da ovatta in fibra di poliestere accoppiata a tessuto 100% poliestere con trattamento Water Repellent (WR) (densità 400 gr/m²) e parte sottostante in rete di filato poliestere (90 gr/m²) - Polyurethane foam (density 25 kg/m³) covered with polyester fiber wadding coupled with 100% polyester fabric with Water Repellent (WR) treatment (density 400 g/m²) and polyester yarn mesh underneath (90 g/m²) - Mousse polyuréthane (densité 25 kg/m³) recouvert d'une ouate de fibres de polyester couplée à un tissu 100% polyester avec traitement hydrofuge (WR) (densité 400 g/m²) et filet filé de polyester en dessous (90 g/m²) - Polyurethanschäum (Dichte 25 kg/m³) mit mit Gewebe aus 100% Polyester mit Water-Repellent-Behandlung (WR) kaschierter Wattebeschichtung aus Polyesterfaser (Dichte 400 g/m²) und tragendem Netzgewebe aus Polyestergarn (90 g/m²) - Espuma de poliuretano (densidad 25 kg/m³) recubierta de guata de poliéster unida a tela 100% poliéster con tratamiento hidrorrepelente (WR) (densidad 400 g/m²) y parte inferior de malla de hilo de poliéster (90 g/m²) - Espuma de poliuretano (densidade 25 kg/m³) revestido com ouate em fibra de poliéster associada a tecido 100% poliéster com tratamento repelente a água (WR) (densidade 400 gr/m²) e parte inferior em rede de filamento de poliéster (90 gr/m²) - Su geçirmezlik (WR) işlemine tabi tutulmuş, %100 polyester kumaş (yoğunluk 400 g/m²) ile birleştirilmiş polyester elyaf dolgu ile kaplanmış ve alt kısım polyester iplik ağında (90 g/m²) poliüretan köpük (yoğunluk 25 kg/m³) - Пенополиуретан (плотность 25 кг/м³), покрытый ватой из полиэфирного волокна,

сопряженной с тканью 100% полиэстер с водоотталкивающей пропиткой (Water Repellent - WR) (плотность 400 г/м²) и подложкой из сетки из полиэфирной пряжи (90 г/м²).

CUSCINO SCHIENALE MAXIMO

CUSCINO SCHIENALE ANGOLO MAXIMO

Poliuretano espanso (densità 17 kg/m³) rivestito da ovatta in fibra di poliestere accoppiata a tessuto 100% poliestere con trattamento Water Repellent (WR) (densità 200 gr/m²) - Polyurethane foam (density 17 kg/m³) covered with polyester fibre wadding coupled with 100% polyester fabric with Water Repellent (WR) treatment (density 200 gr/m²) - Mousse polyuréthane (densité 17 kg/m³) recouvert d'une ouate de fibres de polyester couplée à un tissu 100% polyester avec traitement hydrofuge (WR) (densité 200 g/m²) - Polyurethanschäum (Dichte 17 kg/m³) mit mit Gewebe aus 100% Polyester mit Water-Repellent-Behandlung (WR) kaschierter Wattebeschichtung aus Polyesterfaser (Dichte 200 g/m²) - Espuma de poliuretano (densidad 17 kg/m³) recubierta de guata de fibra de poliéster unida a tela 100% poliéster con tratamiento hidrorrepelente (WR) (densidad 200 g/m²) - Espuma de poliuretano (densidade 17 kg/m³) revestido com ouate em fibra de poliéster associada a tecido 100% poliéster com tratamento repelente a água (WR) (densidade 200 gr/m²) - Su geçirmezlik (WR) işlemine tabi tutulmuş, %100 polyester kumaş (yoğunluk 200 g/m²) ile birleştirilmiş polyester elyaf dolgu ile kaplanmış poliüretan köpük (yoğunluk 17 kg/m³) - Пенополиуретан (плотность 17 кг/м³), покрытый ватой из полиэфирного волокна, сопряженной с тканью 100% полиэстер с водоотталкивающей пропиткой (Water Repellent - WR) (плотность 200 г/м²).

CUSCINO SEDUTA KOMODO

Poliuretano espanso (densità 29 kg/m³) rivestito da fibra di poliestere (densità 450 gr/m²) - Polyurethane foam (density 29 kg/m³) with a polyester fiber coating (density 450 gr/m²) - Mousse polyuréthane (densité 29 kg/m³) revêtu de fibre de polyester (densité 450 gr/m²) - Polyurethanschäum (Dichte 29 kg/m³) mit Polyesterfasern beschichtet (Dichte 450 gr/mm²) - Espuma de poliuretano (densidad 29 kg/m³) cubierta con fibras de poliéster (densidad 450 gr/m²) - Espuma de poliuretano (densidade 29 kg/m³) com cobertura fibras de poliéster (densidade 450 gr/m²) - Polyester elyaf (Yoğunluk 450 gr/m²) kaplı köpük poliüretan (Yoğunluk 29 kg/m³) - Пенополиуретан (Плотность 29 кг/м³) с покрытием из обшивка из полиэстера (Плотность 450 гр/м²).

CUSCINO SCHIENALE KOMODO

CUSCINO SCHIENALE ANGOLO KOMODO

Poliuretano espanso (densità 18 kg/m³) rivestito da fibra di poliestere (densità 450 gr/m²) - Polyurethane foam (density 18 kg/m³) with a polyester fiber coating (density 450 gr/m²) - Mousse polyuréthane (densité 18 kg/m³) revêtu de fibre de polyester (densité 450 gr/m²) - Polyurethanschäum (Dichte 18 kg/m³) mit Polyesterfasern beschichtet (Dichte 450 gr/m²) - Espuma de poliuretano (densidad 18 kg/m³) cubierta con fibras de poliéster (densidad 450 gr/m²) - Espuma de poliuretano (densidade 18 kg/m³) com cobertura fibras de poliéster (densidade 450 gr/m²) - Polyester elyaf (Yoğunluk 450 gr/m²) kaplı köpük poliüretan (Yoğunluk 18 kg/m³) - Пенополиуретан (Плотность 18 кг/м³) с покрытием из обшивка из полиэстера (Плотность 450 гр/м²).

CUSCINO POGGIATESTA FOLIO

CUSCINO POGGIATESTA NET LOUNGE

Fibra di Poliestere rivestito da poliestere water repellent - Polyester fiber coated with water repellent polyester - Fibre de polyester enduite de polyester hydrofuge - Mit wasserabweisendem Polyester beschichtete Polyesterfaser - Fibra de poliéster recubierta de poliéster hidrorrepelente - Fibra de poliéster revestido de poliéster resistente à água - Su geçirmez kaplamalı polyester elyaf - Полиэфирное волокно с водоотталкивающим полиэфирным покрытием.

CUSCINO PASSEPARTOUT - CUSCINO RETTANGOLARE - CUSCINO ARREDO MAXIMO

Fibra di poliestere - Polyester fiber - Fibre de polyester - Polyesterfasern - Fibras de poliéster - Fibras de poliéster - Polyester elyaf - Обшивка из полиэстера.

CUSCINO PLANO

Poliuretano espanso (densità 25 kg/m³) rivestito da tessuto di poliestere con trattamento Water Repellent (WR) - Foamed polyurethane (25 kg/m³ density) upholstered in polyester fabric with Water Repellent (WR) treatment - Polyuréthane expansé (densité 25 kg/m³) recouvert de tissu polyester avec traitement hydrofuge - Polyurethanschäum (Dichte 25 kg/m³), bezogen mit Polyestergewebe mit Water-Repellent-Behandlung (WR) - Espuma de poliuretano (densidad 25 kg/m³) recubierta de tejido de poliéster con tratamiento hidrófugo (WR) - Espuma de poliuretano (densidade 25 kg/m³) revestida com tecido de poliéster com tratamento hidrorrepelente (WR) - Genişletilmiş poliüretan (yoğunluk 25 kg/m³) su itici (WR) işlemli polyester kumaşla kaplanmıştır - Пенополиуретан (плотность 25 кг/м³), покрытый полиэфирной тканью с водоотталкивающей пропиткой (Water Repellent - WR).

synthetic fabric

Tessuto in filo di poliestere rivestito in pvc - Fabric is made of a polyester fiber, with a pvc coating - Tissu en fil de polyester revêtu de pvc - Gewebe aus PVC-ummantelten Polyesterfasern - Tejido en hilo de poliéster recubierto

de pvc - Tecido de fibra polyester com cobertura pvc - PVC kaplı polyester elyaf tekstil - Ткань из полиэфирных нитей с покрытием из ПВХ.

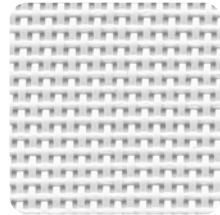

bianco .107
tela 1x1

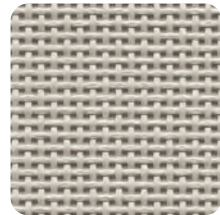

incenso .210
tela 1x1

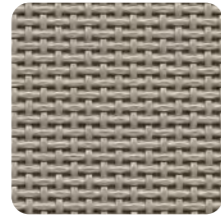

tortora .104
tela 1x1

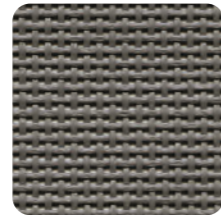

castagno .211
tela 1x1

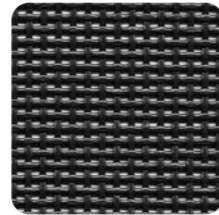

antracite .057
tela 1x1

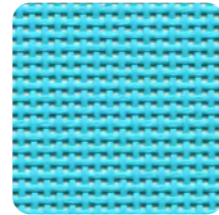

celeste .075
tela 1x1

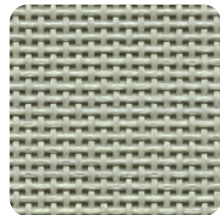

mandorla .212
tela 1x1

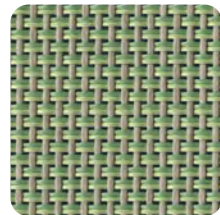

agave .101
tela 2x1

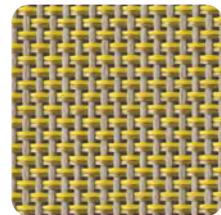

deserto .103
tela 2x1

Cover fabric

56% poliestere e 44% poliuretano. Trattamento idrorepellente, antimacchia, antimuffa e antibatterico. Solidità alla luce 7/8. Lavabile a 95° con detergente neutro - 56% polyester and 44% polyurethane. The treatment makes the coating: water repellent, and resistant to staining, resistant to mold and antibacterial. 7/8 light fastness. Washable at 95° with neutral detergent - 56% polyester et 44% polyuréthane. Traitement hydrofuge, anti-taches, anti-moisissures et antibactérien. Résistance à la lumière 7/8. Lavable à 95° avec un détergent neutre - 56% Polyester und 44% Polyurethan. Wasserabweisend, gegen Flecken und Schimmelbildung ausgerüstet und antibakteriell. Lichtechtheit 7/8. Waschbar bei 95° mit Neutralwaschmit-

tel - 56% poliéster y 44% poliuretano. Tratamiento para repeler el agua, antimanchas, antimoho y antibacteriano. Solidez a la luz 7/8. Lavable a 95° con detergente neutro - 56% de poliéster e 44% poliuretano. Tratamiento hidrorrepelente, antimancha, antimoho e antibacteriano. Resistência à luz 7/8. Lavável a 95° com detergente neutro - % 56 polyester ve % 44 poliüretan. Su Geçirmez Uygulama, kir tutmaz ve küf önleyici uygulama, antibakteriyel uygulama. Işık haslığı 7/8. Naturel deterjanla 95°de yıkanabilir - 56% полиэстер и 44% полиуретан. типы обработки: водоталкивающая,пятноталкивающая,плесеньоталкивающая, и антибактериальная устойчивость к. Светостойкость 7/8. Можно стирать при 95 ° с нейтральным моющим средством.



smoke .204
205 gr/m²

coated aluminium

La verniciatura è a polvere di poliestere - The painting is with polyester powder - La peinture est à poudre de polyester - Die Epoxierung erfolgt mit Polyesterpulver - El pintado se realiza con polvo de poliéster - O pó de

poliester è usado para envernizar - Boyası polyester tozla yapılır - Окраска производится при помощи порошкового полиэстера.



verniciato bianco .53



verniciato antracite .52



verniciato corda .69



verniciato tortora .59

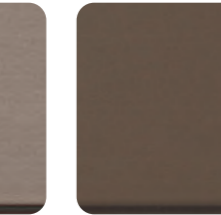

verniciato tabacco .67

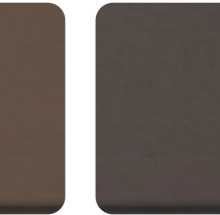

verniciato terra .68

materia laminate HPL Solid Core

Laminato decorativo ad alta pressione, compatto, omogeneo, non poroso, ad alta densità con bordo dello stesso colore del piano -Decorative high pressure laminate, solid, homogeneous, non-porous and with a high density, with the same colour edge as the top - Stratifié décoratif à haute pression, compact, homogène, non poreux, de haute densité avec bord de la même couleur que le plan - Kompaktes, gleichmäßiges, nicht poröses, dekoratives Hochdrucklaminat mit hoher Dichte und Rand in der gleichen Farbe wie die Fläche - Lami-

nado decorativo de alta presión, compacto, homogéneo, no poroso y de alta densidad con canto del mismo color que el tablero - Laminado decorativo de alta pressão, compacto, homogéneo, não poroso, de alta densidade com borda da mesma cor do tampo - Yüksek basınçlı, kompakt, homojen, gözeneksiz, yüksek yoğunluklu dekoratif laminat, tezgahla aynı renkte kenar - Компактный однородный непористый декоративный ламинат высокого давления высокой плотности с каймой того же цвета, что и столешница

Spessore 6 mm, solo per piano PIAVE non ordinabile singolarmente - 6mm thick, only for the PIAVE top, which cannot be ordered separately - Épaisseur de 6 mm, uniquement pour le plan PIAVE qui ne peut pas être commandé individuellement - 6 mm Stärke, nur für die Fläche PIAVE und nicht einzeln bestellbar - Espesor de 6 mm, solo para tablero PIAVE, no se puede pedir por separado - Espessura de 6 mm, apenas para tampo PIAVE, não pode ser encomendado individualmente - 6 mm kalınlık, sadece PIAVE tezgah için, tek başına sipariş edilemez - Толщина 6 мм, только для столешницы PIAVE, отдельному заказу не подлежит



CORDA
MATERIA .369



TORTORA
MATERIA .359

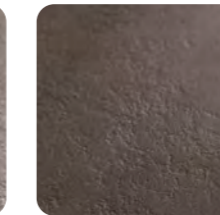

TABACCO
MATERIA .367

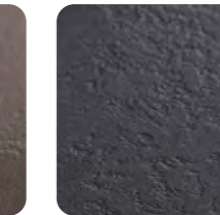

ANTRACITE
MATERIA .352

glass

Vetro extrachiario temperato. Spessore 6 mm - Extra-clear tempered glass. Thickness 6 mm - Verre trempé extra clair. Epaisseur 6 mm - Extra klares gehärtetes Glas. Dicke 6 mm - Vidrio templado extra claro. Espesor 6 mm

- Vidro temperado extra claro. Espessura 6 mm - Ekstra net temperli cam. Kalınlık 6 mm - Особо прозрачное закаленное стекло. Толщина 6 мм.



vetro .501

durelTOP



DurelTOP è un sistema innovativo di produzione di piani per tavoli studiati per raggiungere i più elevati livelli di praticità, resistenza, robustezza ed eleganza. I piani DurelTOP sono ad alto spessore, formati da un doppio strato tamburato perfettamente chiuso. Prodotti in polipropilene di prima qualità, sono inalterabili all'acqua, resistenti al sole e facili da pulire. DurelTOP è il risultato di una lunga ricerca tecnologica e dell'esperienza decennale nella lavorazione delle materie plastiche della NARDI, da sempre all'avanguardia nell'ambiente contract e giardino.

The DurelTOP is an innovative new system in the production of tabletops developed to reach the highest levels of practicality, resistance, and elegance. The DurelTOP tabletops have a greater thickness, formed by a double layer enclosure perfectly closed. Produced in first quality polypropylene, they are resistant to water, resistant to sunlight, and are easy to clean. DurelTOP is a result of a decade's long research and development in plastics by NARDI, always a leader in the contract and garden sectors.

DurelTOP est un système innovateur de production de plateaux de tables, il est étudié pour retrouver le meilleur niveau de pratique de résistance et d'élégance. Les plateaux DurelTOP sont très épais, formés de doubles couches parfaitement finies. Ce sont des produits en polypropylène de première qualité, ils sont inaltérables à l'eau, résistant au soleil et faciles à nettoyer. DurelTOP est le résultat d'une longue recherche technologique et une expérience décennale dans le travail des matières plastique de la Sté NARDI, toujours a l'avant-garde dans le secteur du contract et jardin.

DurelTOP ist ein neu entwickeltes System für die Produktion von Tischplatten, um ein Höchstmaß an Funktionalität, Widerstandsfähigkeit und Eleganz zu erreichen. Durch das innen verstärkte "Zwei-Schichten-Hohlraum-System" erreicht die DurelTOP Tischplatte einen stärkeren Querschnitt und damit ein Höchstmaß an Festigkeit. Hergestellt aus hochwertigem Qualitätspolypropylen ist sie resistent gegen Wasser und Sonnenlicht und dabei leicht zu reinigen. DurelTOP ist das Ergebnis von 10 Jahren Forschung und Entwicklung auf dem Kunststoffsek-

tor durch NARDI, immer der führende im Bereich Contract- und Gartenmöbel. DurelTOP es un nuevo sistema de fabricación de tableros de mesa estudiado para alcanzar los mas altos niveles de practicidad, resistencia, robustez y elegancia. Los tableros DurelTOP de gran solidez, estan formados por una doble capa perfectamente unida y sellada. Fabricados en polipropileno de primera calidad son inalterables al agua, resistentes al sol y de fácil limpieza. DurelTOP es el resultado de una prolongada investigación tecnológica y de la experiencia acumulada en los mas de diez años que NARDI lleva produciendo materias plasticas, siempre innovando en ambientes contract y jardin.

DurelTOP é um sistema de inovação da produção de tampos de mesa concebidos para atingir a máxima resistência,práticos e elegantes. Os tampos de mesa DurelTOP são formados poruma camada dupla e perfeitamente unida. Produzidos em polipropileno de primeira qualidade, são resistentes ao sol e fáceis de limpar. DurelTOP é o resultado de uma longa investigação tecnológica em materiais plásticos da NARDI, leader em mobiliário de jardim.

DurelTOP, masa tablalarının üretiminde kullanılan yeni bir sistem olup, yüksek seviyede pratiklik, direnç ve de ılık sunmak amacıyla geliştirilmiştir. DurelTOP masa tablaları fevkalade bir inceliğe sahip olup, kusursuz kapanan çift tabaka çevirme sistemiyle oluşturulmuştur. Nitelikli çamsakızından üretilmiş olup, suya ve güneş ışığına karşı dirençli ve temizlenmesi kolaydır. DurelTOP sistemini Contract ve de Bahçe sektöründe her zaman lider olan NARDI'nin uzun araştırmalarının sonucundan doğan, plastikte gelişim olarak adlandırabiliriz.

DurelTOP — это инновационная система производства столешниц, позволяющая изготавливать практичные, прочные, крепкие и элегантные столешницы. Столешницы DurelTOP обладают высокой плотностью и состоят из двойной панели с мелкопустотным заполнением, полностью закрытой. Изделия из полипропилен высокого качества устойчивы к воде, солнцу и просты в уходе. DurelTOP — это результат многолетних технологических исследований и десятилетнего опыта NARDI в обработке пластмасс, лидера в производстве садовой мебели и контрактном секторе.

 impilabile - stackable - empilable - stapelbar - apilable - empilhável - istiflenebilir - стекируемые

 reclinabile - reclining - dossier réglable - verstellbare Rückenlehne - inclinable - inclinável - sirt pozisyonlu - откидной

Tutte le sedute sono dotate di piedini antiscivolo - All chairs are equipped with non-slip feet - Tous les sièges sont équipés avec patins anti-dérapants - Alle Stühle sind mit rutschfesten Fußkappen ausgestattet - Todos los asientos están equipados con tapones antideslizantes - Todos os assentos estão equipados com pés antiderrapantes - Bütün sandalyeler kaymaz ayaklıdırlar -Ножки всех стульев оснащены противоскользящей резиновой подложкой

Sui colori scuri, ombre, striature ed altri difetti minori sono più evidenti rispetto ai colori chiari e sono da ritenersi standard. On dark colors, shadows, streaks and other minor faults are more evident than on lighter colors and are therefore standard. Sur les couleurs sombres, les ombres, les stries et les autres petits défauts sont plus marqués que sur les couleurs claires et sont tout à fait standards. Auf dunklen Farben sind Schatten, Streifen und andere kleinere Mängel sichtbarer als auf hellen Farben und sind daher als Standard zu betrachten. Las sombras, rayas y demás defectos menores son más evidentes sobre los colores oscuros respecto a los colores claros y tienen que considerarse como estándares. Em cores escuras, sombras, listras e outros defeitos menores são mais evidentes do que em cores claras e devem ser considerados standard. Koyu renkler üzerinde, gölgeler, çizgiler ve diğer küçük defolar açık renkler üzerinde olduklarından daha belirginleşmekte ve bu nedenle normal olarak değerlendirilmelidirler. По сравнению со светлыми цветами на темных цветах тени полоска и другие небольшие дефекты более заметны и должны считаться нормой.

I "riquadri colore" hanno lo scopo di rappresentare le tonalità dei prodotti per fornirne un'idea viva realistica. Le dimensioni e i pesi dei prodotti hanno una tolleranza di +/- 3%, le dimensioni di imballo hanno una tolleranza di +/- 1 cm per ciascun lato. NARDI si riserva il diritto di apportare modifiche o varianti senza preavviso. Tutti i modelli sono depositati. The 'colour boxes' are intended to represent the shades of the products to provide a realistic visual effect. Product dimensions and weights have a tolerance of +/- 3%, packaging dimensions have a tolerance of +/- 1 cm on each side. NARDI reserves the right to make changes or variations without prior notice. All models have been registered. Les « encadrés de couleurs » sont destinées à représenter les teintes des produits afin de donner une impression visuelle réaliste. Les dimensions et poids des produits ont une tolérance de +/- 3 %, les dimensions des emballages ont une tolérance de +/- 1 cm de chaque côté. NARDI se réserve le droit d'apporter des modifications ou des variations sans préavis. Tous les modèles sont déposés. Die „Farbrechtecke“ sollen die Farbtöne der Produkte darstellen, um eine realistische Vorstellung zu ergeben. Die Abmessungen und die Gewichte der Produkte weisen eine Toleranz von +/- 3 %, die Abmessungen der Verpackung eine Toleranz von +/- 1 cm pro Seite auf. NARDI behält sich das Recht auf Änderungen oder Varianten ohne Vorankündigung vor. Alle Modelle sind hinterlegt. Los «recuadros de color» tienen el objetivo de mostrar los colores de los productos para dar una impresión visual realista. Las medidas y pesos del producto tienen una tolerancia de +/- 3 %, las medidas del embalaje tienen una tolerancia de +/- 1 cm por cada lado. NARDI se reserva el derecho de realizar cambios o variaciones sin previo aviso. Todos los modelos están registrados. As «amostras de cor» têm como objetivo representar as tonalidades dos produtos para dar uma ideia visual realista. As dimensões e os pesos dos produtos têm uma tolerância de +/- 3%, as dimensões da embalagem têm uma tolerância de +/- 1 cm para cada lado. NARDI reserva-se o direito de fazer alterações ou modificações sem aviso prévio. Todos os modelos estão depositados. "Renk kutuları" gerçekçi bir görsel fikir sağlamak için ürünlerin tonlarını temsil etmeyi amaçlamaktadır. Ürünlerin boyutları ve ağırlıkları +/- %3 toleransa sahiptir, ambalaj boyutları her bir taraf için +/- 1 cm toleransa sahiptir. NARDI, bildirimde bulunmaksızın değişiklik veya varyasyon yapma hakkını saklı tutar. Tüm modeller tescillidir. "Прямоугольники цвета" предназначены для представления оттенков изделий с целью создания реалистичного зрительного образа. Размеры и масса изделий имеют допуск +/- 3%, размеры упаковки имеют допуск +/- 1 см с каждой стороны. NARDI оставляет за собой право вносить изменения или выпускать варианты без объявления. Все модели зарегистрированы.

STYLING

Elisa Musso
Studio Salaris
Cristina Nava
Elena Mora

THANKS TO

Aytm
Bitossi Home
Bloomingville
Ichendorf
Incipit Lab
L'Abitare
Normann Copenhagen
Karpeta
Flos Outdoor

GRAPHIC DESIGN PHOTO

Studio Raffaello Galiotto

